



COMPACTTILT™

USER MANUAL
INSTRUCTIONS
PRODUCT INFORMATION

CT1-2 v1.2024

Patent no.: PCT/DK2016/050047



Congratulations on choosing Compacttilt!

We are happy that you have chosen our product - and look forward to it working for you.

Here at Compacttilt, we develop and create products based on the vision of creating the best user experiences. Therefore, it is also important for us that you remain satisfied with your Compacttilt product, and if something unexpected arises or questions - contact us or your machine dealer.

Compacttilt products are our own development and is manufactured in Compacttilt's factory in Denmark. This means that each part of the product is engineered based on our vision of what supplies the best tilt product. But we cannot avoid the fact that maintenance and correct use of the product is the way forward, for full utilization of the product's lifetime. Therefore, read this instruction and perform the maintenance according to the regulations.

Again, congratulations on your choice of Compacttilt. We look forward to a long and good cooperation. Just contact us for more information.

Daniel Duus,
CEO and Product Engineer
Compacttilt.com

Compacttilt is a patented and protected product: The full ownership of all intellectual property rights regarding the product's manufacture, design, trademarks and copyrights, belongs to Compacttilt ApS.

EF- Declaration of conformity

According to The Machinery Directive 2006/42/EF, Appx. IIA



Manufacturer:

Compacttilt ApS
Fabriksvej 5
5580 Nørre Aaby, Danmark
Tlf.: +45 6442 2080

Hereby declare that the following equipment:

Product: Compacttilt™

Type: **CT1-2**

Serie no _____

Year: _____

Complies with the following directives:

2006/42/EC Machinery Directive

2014/30/EU EMC-directive (Electromagnetic Compatibility)

The following harmonized standards have been applied:

DS/EN ISO 12100:2011 Machine safety - General principles of construction - Risk assessment and risk reduction

DS/EN ISO 4413:2010 Hydraulics - General rules and safety requirements for systems and their components.

DS/EN 474-1:2022 Earthmoving machines - Safety - Part 1: General requirements

DS/EN 474-5:2022 Earth-moving machinery - Safety - Part 5: Requirements for hydraulic excavators

ISO 13031:2016 Earth-moving machinery - Quick couplers - Safety

DS/EN ISO 13849-1:2023 Safety of machinery - Safety related parts of control systems - Part 1: General principles of construction

Place / Date

December 2024

Name/Title Maria Gade, Administrator

Signature

The undersigned is the representative for the collection of the technical dossier

Certificate: Lifting Hook

For use and limitations look further down the instructions.



| | | | | | |
|---|----------------------------------|---|---|---|----------------|
| TEST CERTIFICATE | | H-LIFT INDUSTRIES CO., LTD. | | | |
| | | 8/F., No. 560 Jincheng Road, Xiaoshan, Hangzhou, 311202, China Tel + 86-571-8263-6008, Fax + 86-571-8263-6028 http://www.h-lift.com E-mail: info@h-lift.com | | | |
| | | CERTIFICATE NO. | ZS-14319-029 | | |
| | | SUPPLIED TO | SORENSEN & KOFOED A/S SMEDEHOLM 7-9 2730 HERLEV DENMARK | | |
| YOUR P/O NO.: | 00059679-2 | INVOICE NO. | 14HC319 | | |
| (1) Description of Gear | | | | | |
| GRADE 80 WELD ON HOOK TESTING ACCORDING TO EN 1677 MATERIAL: ALLOY STEEL | | | | | |
| (2) PRODUCT CODE | (3) SIZE(t) | (4) QUANTITY (pcs) | (5) WORKING LOAD LIMIT(WLL) | (6) MIN. BREAKING FORCE (BF) | (7) MARKING |
| 8-WOH-01 | 1 | 50 | 1t | 49kN | WLL 1T CE |
| 8-WOH-02 | 2 | 100 | 2t | 98kN | WLL2T CE |
| 8-WOH-03 | 3 | 120 | 3t | 147kN | WLL3T CE |
| 8-WOH-05 | 5 | 40 | 5t | 245kN | WLL5T CE |
| 8-WOH-08 | 8 | 20 | 8t | 392kN | WLL8T CE |
| I hereby certify that the item described in this certificate was tested and thoroughly examined and that the above particulars are correct. | | | | | |
| TEST RESULT | | CERTIFIED BY: | |  | |
| Pass <input checked="" type="checkbox"/> | Fail <input type="checkbox"/> | AUTHORISED SIGNATORY: | | | |
| | | DATE (dd/mm/yy): | | | |
| | | | | 06/09/14 | |



Add: 8/F., No. 560 Jincheng Road, Xiaoshan, Hangzhou, 311202, China
Tel: +86-571-8263-6008 Fax: +86-571-8263-6028 http://www.h-lift.com Email: info@h-lift.com

Content

| | |
|--|----|
| Safety Regulations | 5 |
| Compacttilt: purpose and function..... | 5 |
| Restrictions on use | 5 |
| Before Use | 5 |
| Before Daily Use..... | 5 |
| Intended use..... | 6 |
| Regular security checks Compacttilt! | 7 |
| During inspection and maintenance: | 7 |
| Safety instructions | 7 |
| Warning – Prohibition - Reminders | 8 |
| Moving the product..... | 9 |
| Disposal | 9 |
| Cessation of use and disassembly | 9 |
| Scrapping..... | 9 |
| Installation | 11 |
| Before start of installation | 11 |
| Installation..... | 11 |
| Inspect for unwanted contact between machine and coupler | 12 |
| Hydraulic connection..... | 13 |
| Connection with semi-automated coupler | 13 |
| Connection with hydraulic coupler | 13 |
| Installation inspection | 14 |
| Steering range – Compacttilt..... | 14 |
| Coupling of equipment | 14 |
| Hydraulic quick coupler | 14 |
| Semi-automatic coupler | 15 |
| Decoupling equipment | 17 |
| Lifting hook – use and limitations..... | 18 |
| Safety - coupler | 18 |
| Springs coupler..... | 18 |
| CT-Lock | 18 |
| Lubrication overview | 19 |
| Spare parts..... | 19 |

Safety Regulations

This instruction manual must be thoroughly read by any user of the Compacttilt before use. The Compacttilt may only be used for the purposes described in this manual. Compacttilt is a hydraulic quick-coupling equipment that connects the carrier with an implement - therefore user instructions and safety instructions from these two products must always be understood and complied with before the product is used.

Compacttilt: purpose and function

To give the excavator increased flexibility, so as the Compacttilt is mounted between an excavator's arm and an attachment such as a shovel. Compacttilt adds the function that the attachment can be tilted.

NOTE: The weight of the Compacttilt and the increased range can lead to impaired stability which in the worst case can lead to personal or property damage.

The Compacttilt is only for use in implements intended for excavators and must not be used for other purposes.

Restrictions on use

The Compacttilt is only intended for use with digging implements. It is not recommended to use the Compacttilt for oil hammer / hydraulic hammer, as it significantly reduces the service life of the Compacttilt.

Compacttilt must not be used with a crane arm, for transporting or lifting people.

Before Use

- This instruction only involves the Compacttilt - the safety information described will at all times depend on the carrier, where the applicable safety instructions and lifting graphs for the carrier as well as any other equipment, are to be read and understood at all times before commissioning and subsequently complied with.
- It is ensured that the information in the declaration of conformity corresponds to the information plate mounted on the Compacttilt. If there are deviations, contact the supplier immediately before carrying out the installation.
- Make sure that the hydraulic system is depressurized before you start working on the system.
- It is strictly forbidden, at any time, that:
 - Stay under the Compacttilt.
 - To influence, sabotage or manipulate the Compacttilt using 3rd party objects.
 - To use the Compacttilt for other machine types than the specific one for which it is manufactured, cf. the type plate.

Before Daily Use

- The mounting points are safety components that require regular inspection and adjustment. In the event of signs of wear or cracking, the Compacttilt must not be used.
- Always follow the instructions and pay attention to the personal and environmental instructions in the data sheet that comes with hydraulic oil and grease.
- Never use your hands to check for leaks in the hydraulic system - there is a risk of personal injury.
- When mounting the Compacttilt and / or tool holder, check the limits for tip load.
- Implements connected to the Compacttilt may only be used if the locking has been carried out correctly.

- Never use the Compacttilt on a damaged or defective machine or bucket.
- Never try to increase the maximum capacity of the machine.
- Always replace damaged or unreadable labels and warning signs before using the machine.
- Always insulate electrical conductors and components when installing electrical equipment.
- There is a risk of burns when in contact with hot hydraulic oil.
- The implement lock may only be deactivated when equipment is to be disconnected from the product.
- There is a risk of crushing with moving parts.
- When lifting, use a lifting hook for lifting to the extent that the excavator is approved for.
- If you have any doubts about use and safety instructions, contact your dealer or the manufacturer of the Compacttilt.
- Be extremely careful when handling long objects due to forces due to “live/movable weight” and the increased risk area. Risk of personal injury and property damage.
- The Compacttilt must not be used beyond the maximum capacity.
- It is not permitted to manipulate or otherwise change the installation and / or function of the Compacttilt.
- Maintenance and repair may only be performed by professionally trained personnel.
- Assembly and installation may only be carried out by an authorized workshop.
- Do not start the tool without:
 - The tool is set correctly, including the mechanical locking device is set correctly.
 - It is ensured that hoses, hydraulics etc. does not bother the Compacttilt and its features.
 - The operator and the third party are not under the tool and / or in the working area of the tool, where the hazardous squeezing situation may occur.
 - Be aware of wear on hydraulic hoses. If damaged, make sure to replace.
- Important for tilt with valve system:
 - Always test the valve function before use, to ensure that the valve system is fully functional. This is done by making a full right and full left tilt, then checking that the locking pins are not unlocked when tilting. If this is not the case - contact your service center.
 - Checks for leaks. The Compacttilt must not be used if leaks are found on the valve system.
 - Pay attention to wear on hoses. In the event of signs of wear, these must be replaced immediately.

Intended use

- When installing the Compacttilt and/or mounting bracket, check the tip load limitations.
- Equipment attached to the Compacttilt must only be used if it is locked correctly.
- It is not allowed to manipulate or in any other way to change the Compacttilt's mounting or function.
- Mounting and installation must be carried out at an authorized workshop.

Regular security checks Compacttilt!

During inspection and maintenance:

- Lubrication of lubrication points according to the overview
- Threads and bolts are intact
- Function and state of the quick coupler locking pins
- Eyes and bushings are intact
- No loose bolting joints
- No cracks or fractures
- It is ensured that the quick coupler is clean, and mounted and tightened correctly
- The Compacttilt is correctly mounted between the excavator and the implement
- There is no hydraulic leak
- There is no grease leakage on hoses or couplings

Every month or when needed for inspection and maintenance:

- All bolts and nuts are inspected and tightened
- Check for unusual wear
- Cleaning of hoses and couplings
- Check for abnormal play. If play exceeds 2 degrees, contact your dealer for service.

Annual inspection or after 500 operating hours:

- Inspection must be carried out in accordance with applicable legislation.

Tightening torque:











| Bolt size [mm] | Torque [NM] (10.9 bolts) | Torque [NM] (12.9 bolts) |
|----------------|--------------------------|--------------------------|
| M5 | 8.1 | 9,7 |
| M6 | 14 | 17 |
| M8 | 33 | 40 |
| M10 | 65 | 79 |
| M12 | 114 | 136 |
| M14 | 181 | 217 |
| M16 | 277 | 333 |

Safety instructions

- Only trained personnel and operators above the age of 18 are allowed to operate the product.
- The machine bracket must be properly mounted. Any irregularities must be reported and fixed.
- All operators must be registered by the person in charge of the excavator.
- During maintenance all moving parts must be in a locked position.
- During maintenance the manufacturer demands that the operator uses correct safety equipment.

| | | | |
|---|---|--|---|
|  |  |  |  |
| <p>High pressure fluid.</p> <p>The pump generates high pressure fluid. Never check for leaks with a hand or other body part. Always drain pressure before working on the hydraulic system</p> | <p>Safety glasses required</p> | <p>Wear safety boots</p> | <p>Keep at safe distance from hazard</p> |

Warning – Prohibition - Reminders

-  This manual must be available immediately at the machine. If this is not possible, the machine must clearly mark where the manual is stored.
-  Other rules established by national or other authorities or by the company itself must be observed. If these are violated, the manufacturer and his representative disclaim any responsibility for damage to persons or material.
-  The machine must be operated in accordance with the instructions and instructions given in this and the other instructions that together constitute the operating instructions for the machine.
-  This manual must be read before using the machine.
-  All operators and others who must operate the machine must review this manual before working on the machine. By operator's means all people working at the machine, both operators and employees who are engaged in, e.g. unloading and loading, cleaning, maintenance etc.
-  Only those people who need it as part of their work may access the machine. If it is necessary to provide access to the machine for people unfamiliar with the function (e.g. during repairs, visits or demonstrations), this must be done under the pre-determined safety precautions. The person responsible for the operation of the machine must be informed of the presence of strangers.
-  Operators and repairers who are to operate or work on the machine must undergo training in the use of the machine before the work may take place. The manufacturer carries out the necessary training of operators and repairers when handing over the machine.
-  If the safety instructions are ignored by the user, the manufacturer and his representative disclaim all responsibility.
-  If the user changes, disassembles or adds to the original design, mechanical shielding, electrical safety, pneumatics, hydraulics, as well as functions related to the original design, the manufacturer's CE marking lapses.
-  Always test the acoustic signal at every engine start, to ensure correct attachment of equipment on the Compacttilt. This must be conducted regularly to prevent personal injury.

**The manufacturer requires inspection of the products mounting and installation.
The manufacturer requires inspection of the quick coupler locking component.
If damage occurs, contact Support.**

Moving the product

Always ensure that there are no objects, people or third-party objects under the product, or with the risk that it may interfere with the movement.

When moving, use correct lifting devices, e.g. truck or crane. Always remember to ensure that the product is properly secured during the move. It is the user's responsibility that lifting straps, or lifting chains, are safety approved for the weight of the product. For truck transport, machine parts must be secured with straps. For crane lifting, lifting chains / straps must be designed for the weight.

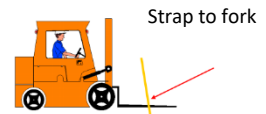

Disposal

Cessation of use and disassembly

- The equipment must not be pressurized during disassembly and must be drained of oil.
- A plan for disassembly must be prepared. The plan must include a risk assessment for the work and for disposal of the Compacttilt machine part.
- Plan and risk assessment must be prepared in accordance with applicable rules at the time of dismantling.



Scrapping

The product is dismantled and sorted into categories that require in applicable environmental requirements. The product is subject to a valid version of: Directive 2008/98/EC on waste.

When the product is obsolete, all the components that make up the Compacttilt machine part must be sorted and handed in at an approved recycling site or conducted by an approved recycling company.

The product must not be disposed of as unsorted household waste. Use the local WEEE collection points for the disposal of electrical components of this product and make sure that all relevant regulations are observed.

The Compacttilt consists of the following parts and must be sorted accordingly:

- Iron
- Aluminum
- Plastic (hard & soft)
- Rubber
- Oil & grease
- Electrical components
- Copper
- Other metals

If parts of a Compacttilt are resold for purposes other than disposal, it is the owner's responsibility to make the recipient aware of the disposal rules.

Technical data Compacttilt

| Data/Compacttilt model | CT1 S30-150 | CT1 MH30 | CT1 S30-180 |
|---|-------------|-----------|-------------|
| Max machine weight | 1200 kg | 1200 kg | 1200 kg |
| Min. installation height [H] | 165mm | 165mm | 165mm |
| Width [B] | 148mm | 192mm | 178mm |
| Length [L] | 256mm | 256mm | 286mm |
| Weight [min] | 21 kg | 22,5 kg | 23 kg |
| Total swing angle [Tilt] | 100° | 100° | 100° |
| Tilt angle | 2x50° | 2x50° | 2x50° |
| Max. Hydraulic pressure [MPa] | 25 | 25 | 25 |
| Recommended Hydraulic Flow [L / min] | 2-4 | 2-4 | 2-4 |
| Torque [Nm at 210bar] | 2035 | 2035 | 2035 |
| Type of coupler | S30-150 | MH30 | S30-180 |
| Max. Excavation torque [kNm] | 13,9 | 13,9 | 13,9 |
| Max. Breaking torque [kNm] | 6,9 | 6,9 | 6,9 |
| * Max. Digging and breaking torque is calculated in relation to the following bucket size. Width height | 500/550mm | 500/550mm | 500/550mm |

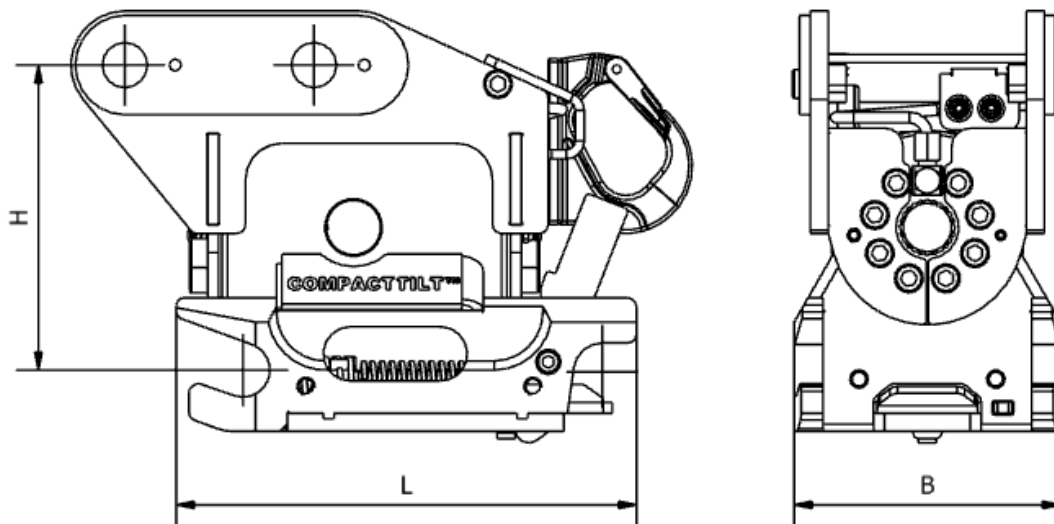

Installation

Documentation for the excavator must be available and is complied with before installation.

In the following it is described how to mount the Compacttilt directly on the excavator. If the Compacttilt is mounted on a quick coupler, and therefore detachable, you must use the excavator documentation.

NOTE: Assembly and installation may only be carried out by workshops approved by the manufacturer. Do not make any changes to the assembly without the manufacturer's permission. Workshops approved by the manufacturer are dealers with their own workshop, unless otherwise stated in the delivery of the Compacttilt.

Before start of installation

Check the limits for tip load considering the weight of the Compacttilt and the extended range, which may make it necessary to reduce, for example, the volume of the bucket.

Place the Excavator on a level and non-slip surface.

Place the bottom of the Compacttilt on a level and non-slip surface, making sure the tilt is in neutral position (**Figure 1**).

The digging arm is maneuvered into position so that the arm can be lowered against the machine mount of the Compacttilt without contact.



Figur 1

Installation



Figur 2

Position the link arm so that its pin bolt hole is in line with the attachment (**Figure 2**).



Figur 3

Mount the pinbolt of the link arm and lock it to the attachment (**Figure 3**).

Note. Use the supplied pin bolts and shims, if supplied.

Lower the main arm into the bracket until its pin hole is in line with the mounting holes in the attachment.

The arm is also locked with a pinbolt corresponding to the link (**Figure 4**).



Figur 4

Inspect for unwanted contact between machine and coupler

It's recommended to look for interference between tilt and boom. Position 1,2,3 and 4 shows where it typically can occur. If no unwanted contact is detected, the installation can continue.

In case of any deviations, please contact Compacttilt on Support@compacttilt.com.



Hydraulic connection

Before starting the installation of hydraulic hoses, the machine must be switched off and the hydraulic system pressureless. Hoses are installed so that there is no squeezing or risk of squeezing when using the machine and connected equipment.

Connection with semi-automated coupler

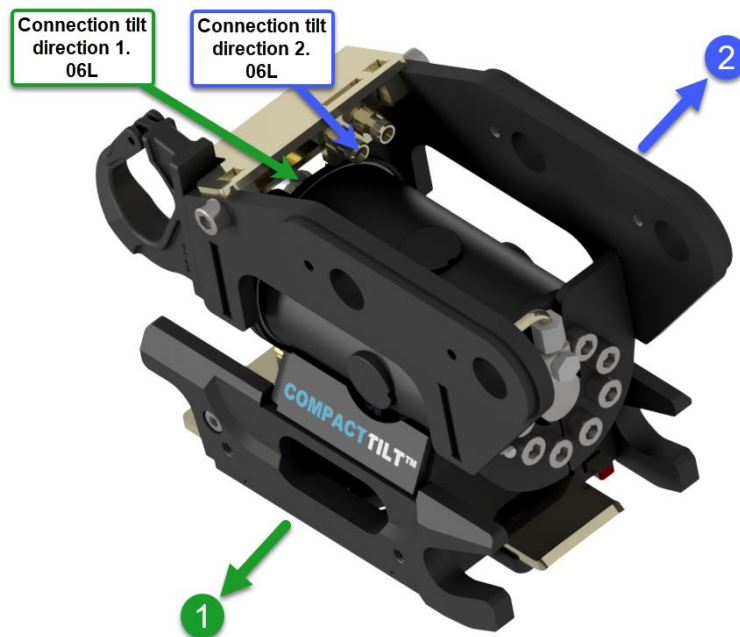

Connection with hydraulic coupler

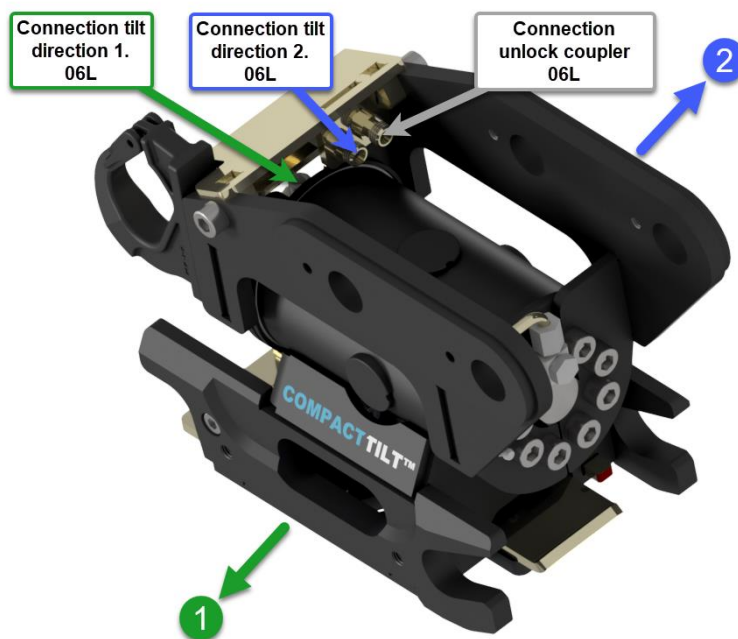

Installation inspection

1. Check that the Compacttilt functions correctly.
2. Check that hoses and electric cables are not at risk of being pinched or stretched.
3. Check for hydraulic leaks.
4. Check that fasteners are properly tightened [see machine instructions].
5. Check that there is no contact with the digging arm and the Compacttilt at full swing.
6. Check that the tilt mounting bracket fits the carrier machine [see type plate].
7. Ensure that the coupler is fully engaged, and the indicator pin is correctly mounted.

Steering range – Compacttilt

Compacttilt has the following control angle which must be taken into account:

1. Tilt 2 x 50° (*Figure 5*)

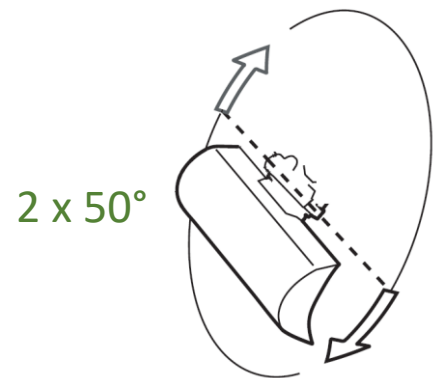

Figure 5

Coupling of equipment

Hydraulic quick coupler

Before coupling the equipment, make sure that the lock is retracted, which can be seen by the indicator pin being pushed out (*Figure 6*).



Figure 7

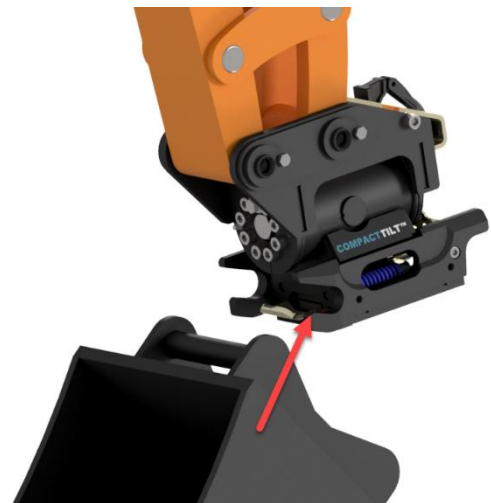

Figure 6

The equipment to be connected must be placed so the coupler's fork eyes can catch.

The quick coupler fork eyes engage the coupling shaft of the equipment (*Figure 7*).

When the quick coupler fork eyes have caught, the equipment is swung into place thus it abuts the open fork eyes of the quick coupler. The quick coupler is activated, and the locking pawl is slid out (**Figure 8**).

The activation of the quick coupler can be seen by the red indicators being retracted.

The machine is now ready for use with the attached equipment.

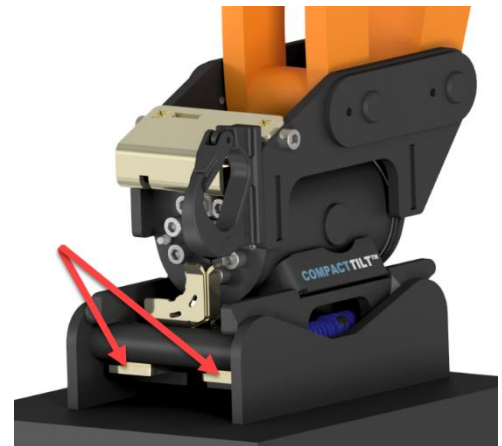

Figure 8

Semi-automatic coupler

Before coupling the equipment, make sure that the lock is retracted, which can be seen by the indicator pin being pushed out

This is done by mounting the included pipe to the coupler activation arm (**Figure 9**).



Figure 9

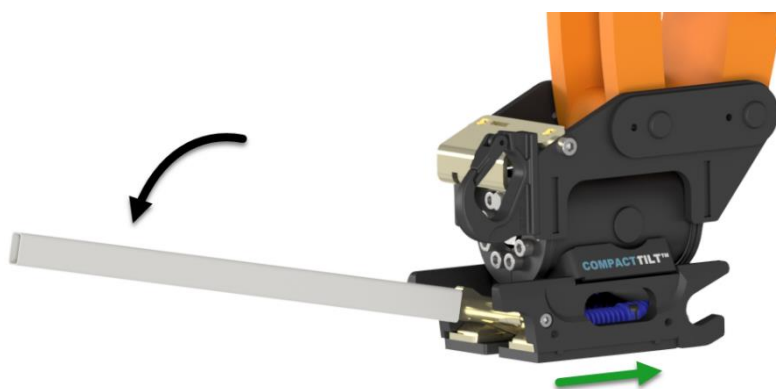

Figure 10

The pipe is pushed downwards until it hits a stop, whereby the coupler is unlocked (**Figure 10**).

The pipe can now be removed, and the coupler will stay unlocked.

The equipment to be connected must be placed so the coupler's fork eyes can catch (*Figure 11*).



Figure 11

When the equipment is swung into place, the equipment shaft will hit the lock activation arm, and thereby activate the lock (*Figure 12*).

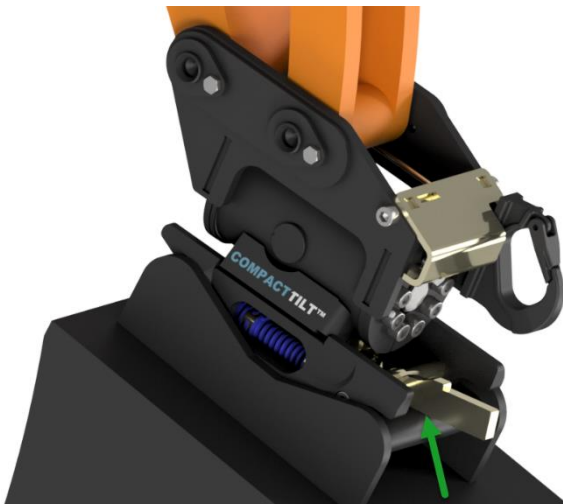

Figure 12

The locking is completed when the activation arm is in the illustrated position, and the indicator is retracted (*Figure 13*).

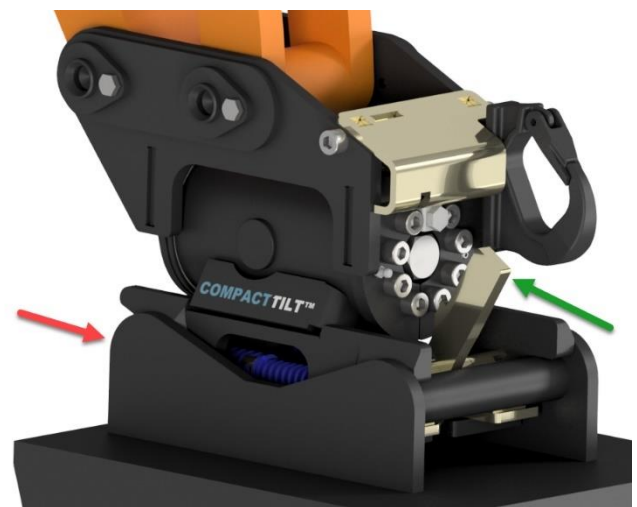

Figure 13

The machine is now ready for use with the attached equipment.

Decoupling equipment

The bucket / equipment is lowered so that it supports a solid surface (*Figure 14*).



Figure 14



Figure 15

The coupler is unlocked by the operator until the red indicator has been extended. This releases the tilt locking pawls from the equipment (*Figure 15*).

With the coupler lock open, the tilt is now moved away from the bucket / equipment (*Figure 16*).



Figure 16

Lifting hook – use and limitations

This illustration (*Figure 17*) is taken from the standard *DS/EN 474-1*, and describes how the lifting hook (*Figure 18*) must be used. See the inscription on the hook for max. capacity load. Human lifting is prohibited.

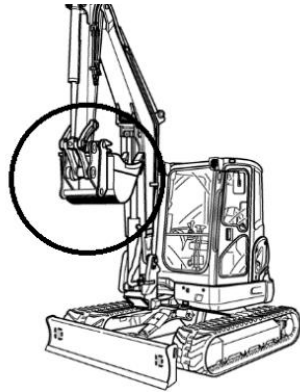

Figure 17



Figure 18

Safety - coupler

Springs coupler

The Compacttilt coupler locks with heavy duty springs.

The Compacttilt must not be used if the springs are damaged or missing.



CT-Lock

The Compacttilt is equipped with CT-Lock, to ensure that equipment that is being attached can't be dropped, in case the equipment is put into use, without being maneuvered correctly into place, before the quick coupler is locked.

The Compacttilt must not be used, if components in relation to the CT-Lock are damaged or missing.

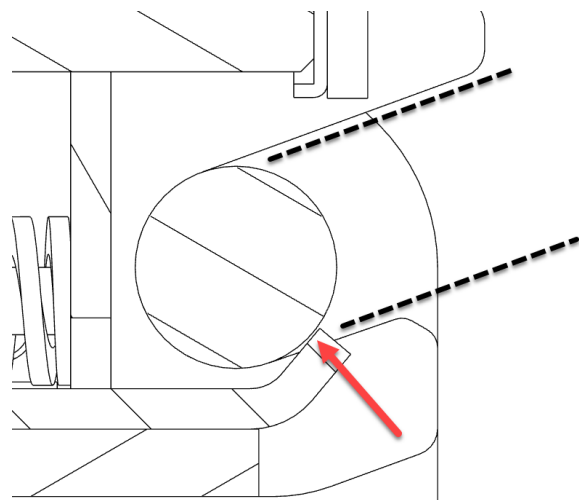

Lubrication overview

For lubrication of the Compacttilt, it is recommended to use: **Castrol Molub-Alloy 370-2**
Lithium-based high-pressure grease with min. 3% molybdenum disulphide (MoS₂) EP additives in NLGI 2.

Spec.: -DIN 51502 KF2K-25
 -ISO 6743-9 ISO-LXCCIB2

Greases containing graphite and copper must not be used.

Always ensure that the lubrication nipples are free of dirt before lubrication is carried out.



Spare parts

Contact your machine dealer for inquiries about spare parts for the Compacttilt.

CT

Become a part of
Compactilt's forum:



You can see many
more pictures here:



Watch all movies from
Compactilt™ here:



Link you to
Compactilt's network here:

