



COMPACTTILT™ ROTATOR™

USER MANUAL
INSTRUCTIONS
PRODUCT INFORMATION

CTR10-1 V1.2024

Patent no.:
PCT/DK2016/050047



Congratulations on choosing Compacttilt!

We are happy that you have chosen our product - and look forward to it working for you.

Here at Compacttilt, we develop and create products based on the vision of creating the best user experiences. Therefore, it is also important for us that you remain satisfied with your Compacttilt product, and if something unexpected arises or questions - contact us or your machine dealer.

Compacttilt products are our own development and is manufactured in Compacttilt's factory in Denmark. This means that each part of the product is engineered based on our vision of what supplies the best tilt product. But we cannot avoid the fact that maintenance and correct use of the product is the way forward, for full utilization of the product's lifetime. Therefore, read this instruction and perform the maintenance according to the regulations.

Again, congratulations on your choice of Compacttilt. We look forward to a long and good cooperation. Just contact us for more information.

Daniel Duus,
CEO and product developer
Compacttilt.com

Compacttilt is a patented and protected product: The full ownership of all intellectual property rights regarding the product's manufacture, design, trademarks and copyrights, belongs to Compacttilt ApS.

EF- Declaration of conformity

According to The Machinery Directive 2006/42/EF, Appx. IIA



Manufacturer:

Compacttilt ApS
Fabriksvej 5
5580 Nørre Aaby, Danmark
Tlf.: +45 6442 2080

Hereby declare that the following equipment:

Product: Compacttilt™
Type: **CTR10**

Serie no _____

Year: _____

Complies with the following directives:

2006/42/EC Machinery Directive
2014/30/EU EMC-directive (Electromagnetic Compatibility)

The following harmonized standards have been applied:

DS/EN ISO 12100:2011 Machine safety - General principles of construction - Risk assessment and risk reduction
DS/EN ISO 4413:2010 Hydraulics - General rules and safety requirements for systems and their components.
DS/EN 474-1:2022 Earthmoving machines - Safety - Part 1: General requirements
ISO 13031:2016 Earth-moving machinery - Quick couplers - Safety
DS/EN ISO 13849-1:2023 Safety of machinery - Safety related parts of control systems - Part 1: General principles of construction

Place / Date

December 2023

Name/Title Maria Gade, Administrator

Signature

The undersigned is the representative for the collection of the technical dossier

Certificate: Lifting Hook

Regarding use and limitations look further down the manual



TEST CERTIFICATE		H-LIFT INDUSTRIES CO.,LTD.			
		8/F., No. 560 Jincheng Road, Xiaoshan, Hangzhou, 311202, China Tel + 86-571-8263-6008, Fax + 86-571-8263-6028 http://www.h-lift.com E-mail: info@h-lift.com			
		CERTIFICATE NO.		ZS-14319-029	
		SUPPLIED TO		SORENSEN & KOFOED A/S SMEDEHOLM 7-9 2730 HERLEV DENMARK	
YOUR P/O NO.:	00059679-2	INVOICE NO.	14HC319		
(1) Description of Gear					
GRADE 80 WELD ON HOOK TESTING ACCORDING TO EN 1677 MATERIAL: ALLOY STEEL					
(2) PRODUCT CODE	(3) SIZE(t)	(4) QUANTITY (pcs)	(5) WORKING LOAD LIMIT(WLL)	(6) MIN. BREAKING FORCE (BF)	(7) MARKING
8-WOH-01	1	50	1t	49kN	WLL1T CE
8-WOH-02	2	100	2t	98kN	WLL2T CE
8-WOH-03	3	120	3t	147kN	WLL3T CE
8-WOH-05	5	40	5t	245kN	WLL5T CE
8-WOH-08	8	20	8t	392kN	WLL8T CE
I hereby certify that the item described in this certificate was tested and thoroughly examined and that the above particulars are correct.					
TEST RESULT		CERTIFIED BY:			
Pass <input checked="" type="checkbox"/>	Fail <input type="checkbox"/>	AUTHORISED SIGNATORY:			
		DATE (dd/mm/yy):			
				06/09/14	



Add: 8/F., No. 560 Jincheng Road, Xiaoshan, Hangzhou, 311202, China

Tel: +86-571-8263-6008 Fax: +86-571-8263-6028 http://www.h-lift.com Email: info@h-lift.com

Content

Compacttilt: purpose and function.....	5
Restrictions on use	5
Before use	5
Before daily use.....	5
Intended use.....	6
Regular security checks Compacttilt Rotator!	6
During inspection and maintenance:	6
Safety instructions	7
Moving the product.....	9
Disposal	9
Cessation of use and disassembly	9
Scrapping.....	9
Data Compacttilt Rotator.....	10
Installation	10
Before start of installation	11
Installation.....	11
Inspect for unwanted contact between machine and coupler	12
Hydraulic diagram CTR10 hydraulic system HS4.....	14
Installation of CTR10 hydraulic system HS4 HF	15
Hydraulic diagram CTR10 hydraulic system HS4 High Flow.....	16
Installation CTR10 hydraulic system HS8.....	17
Hydraulic diagram CTR10 hydraulic system HS8.....	18
Installation CTR10 hydraulic system HS8 HF	19
Hydraulic diagram CTR10 hydraulic system HS8 High Flow	20
Manuel switch between gripper and extra outlet	21
Connection of equipment.....	22
Quick coupler with valve system	23
Steering range – Compacttilt Rotator.....	23
Extra outlet	24
Lifting hook – use and limitations.....	24
Application	24
Gripper – Use and restrictions.....	25
Use.....	25
Restrictions.....	25
Risk	25

This instruction manual must be thoroughly read by any user of the Compacttilt before use. The Compacttilt may only be used for the purposes described in this manual. The Compacttilt is a quick-coupling equipment that connects the carrier with an implement - therefore user instructions and safety instructions from these two products must always be understood and complied with before the product is used.

Compacttilt: purpose and function

- To give the excavator increased flexibility, so as the Compacttilt is mounted between an excavator's arm and an attachment, Compacttilt adds the function that the attachment can be tilted and rotated.
- NOTE: The weight of the Compacttilt and the increased range can lead to impaired stability which in the worst case can lead to personal or property damage.
- The Compacttilt is only for use in implements intended for excavators and must not be used for other purposes.

Restrictions on use

The Compacttilt is only intended for use with digging implements. It is not recommended to use the Compacttilt for oil hammer / hydraulic hammer, as it significantly reduces the service life of the Compacttilt.

Compacttilt must not be used with a crane arm, for transporting or lifting people.

Before use

- This instruction only involves the Compacttilt - the safety information described will at all times depend on the excavator, where the applicable safety instructions and lifting graphs for the excavator as well as any other equipment, is to be read and understood at all times before commissioning and subsequently complied with.
- It is ensured that the information in the declaration of conformity corresponds to the information plate mounted on the Compacttilt. If there are deviations, contact the supplier immediately before carrying out the installation.
- Never attempt to raise the excavator's maximum capacity.
- Make sure to insulate the electric connectors and component when installing electric equipment.
- Maintenance and repairs must be carried out by trained professionals.
- The hydraulic quick coupler may only be activated during change of equipment.
- When lifting, use the lifting hook to the extend the excavator is approved.
- If any doubt occurs regarding the use- and safety specification, contact the dealer or manufacturer of the Compacttilt product.
- Be aware of the risk of squeezing/pinching by moving parts.
- It is strictly forbidden, at any time, to:
 - Stay under the Compacttilt Rotator when mounted on an excavator.
 - To influence, sabotage or manipulate the Compacttilt Rotator using 3rd party objects.
 - To use the Compacttilt for other machine types than the specific one for which it is manufactured, cf. the type plate.

Before daily use

- The mounting points are safety components that require regular inspection and adjustment. In the event of signs of wear or cracking, the Compacttilt must not be used.

- Always follow the instructions and pay attention to the personal and environmental instructions in the data sheet that comes with hydraulic oil and grease.
- Never use your hands to check for leaks in the hydraulic system - there is a risk of personal injury.
- Never use the Compacttilt on a damaged or defective excavator or equipment.
- Always replace damaged or unreadable labels and warning signs before using the machine.
- There is a risk of burns when in contact with hot hydraulic oil.
- Make sure the hydraulic system is depressurized before carrying out work on the system.
- Maintenance and repairs must be carried out by trained professionals.
- Be extremely careful when handling long objects due to forces due to “live/movable weight” and the increased risk area. Risk of personal injury and property damage.
- The Compacttilt must not be used beyond the maximum capacity.
- Do not use the tilt rotator without:
 - The tilt rotator and the hydraulic coupler is adjusted correctly.
 - It is ensured that hoses, hydraulics etc. does not bother the Compacttilt and its features.
 - The operator and the third party are not under the tool and / or in the working area of the tool, where the hazardous squeezing situation may occur.

Important for tilt rotators valve system:

Always test the valve function before use, to ensure that the valve system is fully functional. This is done by making a full right and full left tilt, then checking that the locking pins are not unlocked when tilting. If this is not the case - contact your service center.

Checks for leaks. Compacttilt Rotator must not be used if leaks are found on the valve system.

Pay attention to wear on hoses. In the event of signs of wear, these must be replaced immediately.

Intended use

- When installing the Compacttilt Rotator and/or mounting bracket, check the tip load limitations.
- Equipment attached to the Compacttilt Rotator must only be used if it is locked correctly.
- It is not allowed to manipulate or in any other way to change the Compacttilt Rotator’s mounting or function.
- Mounting and installation must be carried out at an authorized workshop.

Regular security checks Compacttilt Rotator!

During inspection and maintenance:

- Lubrication of lubrication points according to the overview
- Threads and bolts are intact
- Function and state of the quick coupler locking pins
- Eyes and bushings are intact
- No loose bolting joints
- No cracks or fractures
- It is ensured that the quick coupler is clean, and mounted and tightened correctly
- Compacttilt Rotator is correctly mounted between the excavator and the implement
- There is no hydraulic leak
- There is no grease leakage on hoses or couplings

Every month or when needed for inspection and maintenance:

- All bolts and nuts are inspected and tightened
- Check for unusual wear
- Cleaning of hoses and couplings
- Check for abnormal play. If play exceeds 2 degrees, contact your dealer for service.

Annual inspection or after 500 operating hours:

- Inspection must be carried out in accordance with applicable legislation.

Tightening torque:





Bolt size [mm]	Torque [NM] (10.9 bolts)	Torque [NM] (12.9 bolts)
M5	8.1	9,7
M6	14	17
M8	33	40
M10	65	79
M12	114	136
M14	181	217
M16	277	333

The manufacturer requires attachment control damage occurs, contact service support

The manufacturer requires inspection of the products mounting and installation.

The manufacturer requires inspection of the quick coupler locking component. If damage is detected, contact service. The excavator must not be used until it is repaired.

Safety instructions

			
<p>High pressure fluid</p> <p>The pump generates high pressure fluid. Never check for leaks with a hand or other body part. Always drain pressure before working on the hydraulicsystem</p>	<p>Safety glasses needed</p>	<p>Wear safety boots</p>	<p>Stay on safe distance from hazard</p>

- Only trained personnel and operators above the age of 18 are allowed to operate the product.
- The operator must be aware of correct mounting of the product before use.
- The machine bracket must be properly mounted. Any irregularities must be reported and fixed.
- All operators must be registered by the person in charge of the excavator.
- During maintenance all moving parts must be in a locked position.
- During maintenance the manufacturer demands that the operator uses correct safety equipment

Warning – Prohibition - Reminders

This manual must be available immediately at the machine. If this is not possible, the machine must clearly mark where the manual is stored.

 Other rules, established by national or other authorities or by the company itself, must be observed. If these are violated, the manufacturer and his representative disclaim any responsibility for damage to persons or material.

 The machine must be operated in accordance with the instructions and instructions given in this and the other instructions that together constitute the operating instructions for the machine.

 This manual must be read before using the machine.
All operators and others who must operate the machine must review this manual before working on the machine. By operators is meant all persons working at the machine, both operators and employees who are engaged in e.g. unloading and loading, cleaning, maintenance etc.

Only those persons who need it as part of their work may access the machine.

 If it is necessary to provide access to the machine for persons unfamiliar with the function (eg during repairs, visits or demonstrations), this must be done under the pre-determined safety precautions. The person responsible for the operation of the machine must be informed of the presence of strangers.

 Operators and repairers who are to operate or work on the machine must undergo training in the use of the machine before the work may take place. The manufacturer carries out the necessary training of operators and repairers when handing over the machine.

If the safety instructions are ignored by the user, the manufacturer and his representative disclaim all responsibility

 If the user changes, disassembles or adds to the original design, mechanical shielding, electrical safety, pneumatics, hydraulics, as well as functions related to the original design, the manufacturer's CE marking lapses.

- Only instructed personnel may operate the machine part.
- The operator must pay attention to proper fastening of the machine part before start-up.
- The machine part must not be installed with irregularities and must be notified to the person in charge immediately.
- Everyone who operates the part must be registered by the person in charge.
- When working and repairing, all moving functions must be in the locked stop.
- When working with the machine part, the manufacturer requires operators to have personal protection.

Moving the product

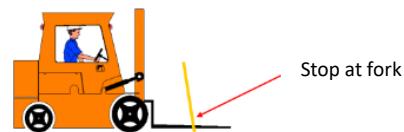

Always ensure that there are no objects, persons or third-party objects under the product, or with the risk that it may interfere with the movement.

When moving, use correct lifting devices, e.g. truck or crane. Always remember to ensure that the product is properly secured during the move. It is the user's responsibility that lifting straps, or lifting chains, are safety approved for the weight of the product. For truck transport, machine parts must be secured with straps. For crane lifting, lifting chains / straps must be designed for the weight.

Disposal

Cessation of use and disassembly

- The equipment must not be pressurized during disassembly and must be drained of oil.
- A plan for disassembly must be prepared. The plan must include a risk assessment for the work and for disposal of the Compacttilt Rotator / machine part.
- Plan and risk assessment must be prepared in accordance with applicable rules at the time of dismantling.



Scrapping

The product is dismantled and sorted into categories that require in applicable environmental requirements. The product is subject to valid version of: Directive 2008/98/EC on waste.

When the product is obsolete, all the components that make up the Compacttilt Rotator / machine part must be sorted and handed in at an approved recycling site or conducted by an approved recycling company.

The product must not be disposed as unsorted household waste. Use the local WEEE collection points for the disposal of electrical components of this product and make sure that all relevant regulations are observed.

The Compacttilt Rotator or tilt consists of the following parts and must be sorted accordingly:

- Iron
- Aluminum
- Plastic (hard & soft)
- Rubber
- Oil & grease
- Electrical components
- Copper
- Other metals

If parts of a Compacttilt are resold for purposes other than disposal, it is the owner's responsibility to make the recipient aware of the disposal rules.

Data Compacttilt Rotator

Data/Compacttilt Rotator	CTR10 – ex. claw	CTR10 – incl. Claw
Max machine size by weight	10.000 kg	10.000 kg
Product installation height [H]	450mm	450mm
Width [B]	390mm	490mm
Length [L]	511mm	511mm
Weight including attachment and valve system	280 kg	320 kg
Total tilt angel [Tilt]	100°	100°
Tilt angle	2x50°	2x50°
Max. Hydraulic pressure [MPa]	22	22
Recommended hydraulic flow [l/min]	45	45
Pressure open/close pin-lock [kN]	1	1
Torque [Nm at 21 MPa]	9437	9437
Type of quick coupler	H45	H45
Rotation ability	∞	∞
Rotator speed [sec/rev. v. 20 l/min]	7	7
Outlet [set]	1	1
Extra outlet [l/min]	80	80
Electrical system	12/24V	12/24V
Max digging moment [kNm]	62,1	62,1
Max. Breaking moment [kNm]	38,4	38,4
*Maks. Digging and breaking moment is calculated at bucket size width/height	600/950mm	600/950mm

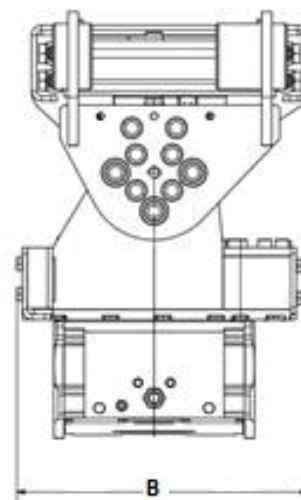
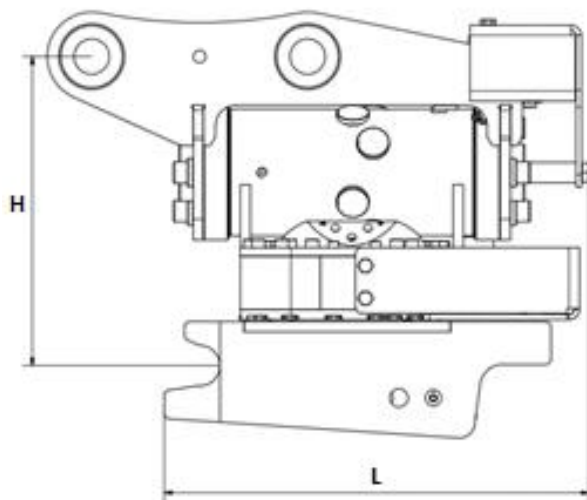

Installation

Documentation for the excavator must be available and is complied with before installation.

In the following it is described how to mount the Compacttilt Rotator directly on the excavator. If the Compacttilt Rotator is mounted on a quick coupler, and therefore detachable, you must use the excavator documentation.

Before start of installation

1. Check the limits for tip load considering the weight of the Compacttilt Rotator and the extended range, which may make it necessary to reduce, for example, the volume of the bucket.
2. Place the Excavator on a level and non-slip surface.
3. Place the bottom of the Compacttilt Rotator on a level and non-slip surface, making sure the tilt is in neutral position (**Figure 1**). The digging arm is maneuvered into position so that the arm can be lowered against the machine mount of the Compacttilt Rotator without contact.



Figure 1

Installation



Position the link arm so that its pin bolt hole is in line with the attachment (**Figure 2**).

Figure 2

Fit the pin bolt and lock it with a bolt to the attachment (**Figure 3**).

Note. Use the included pin bolts if they were delivered with the Compact Tiltrotator.



Figure 3



Figure 4

Lower the main arm into the bracket until its pin hole is in line with the mounting holes in the attachment.

The arm is also locked with a pinbolt corresponding to the link (**Figure 4**).

Inspect for unwanted contact between machine and coupler

It's recommended to look for interference between tilt and boom. Position 1,2,3 and 4 shows where it typically can occur. If no unwanted contact is detected, the installation can continue.

In case of any deviations, please contact Compacttilt on Service@compacttilt.com.

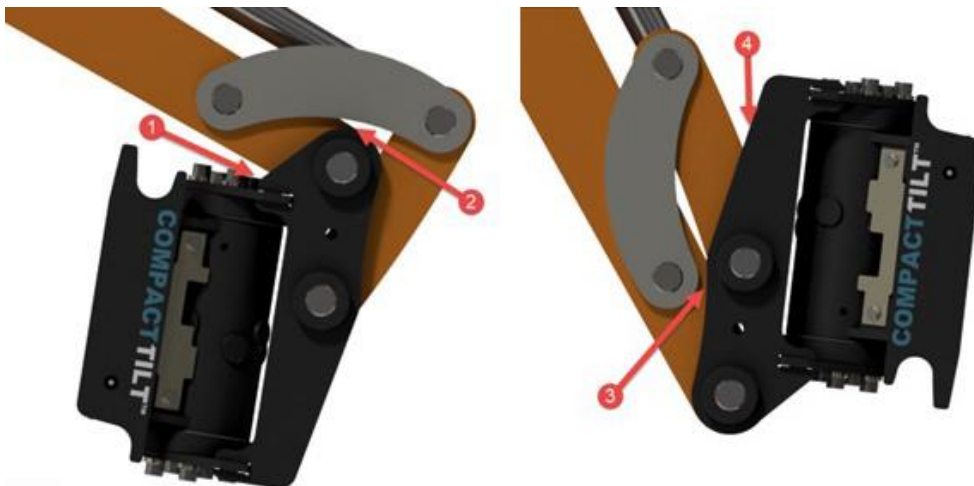

Installation of CTR10 hydraulic system HS4

Before starting the installation of hydraulic hoses, the machine must be switched off and the hydraulic system pressure less.

Hoses are pulled so that there is no squeezing or risk of squeezing when using the machine and connected equipment.

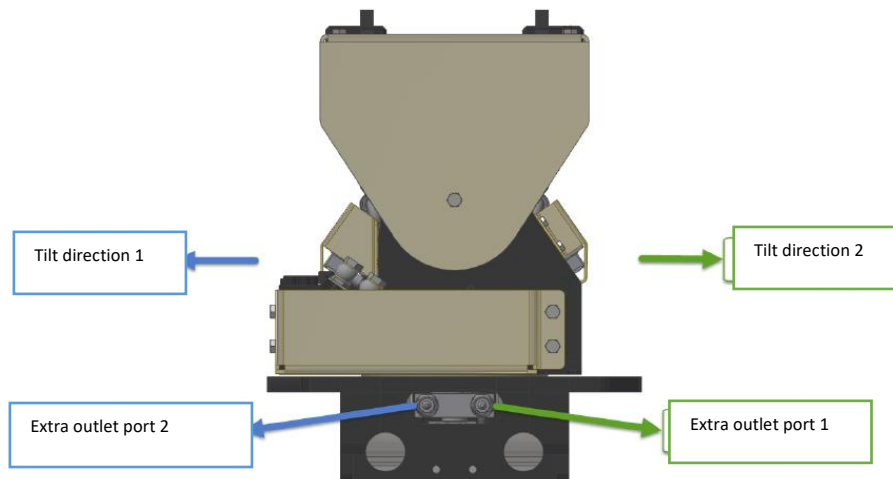
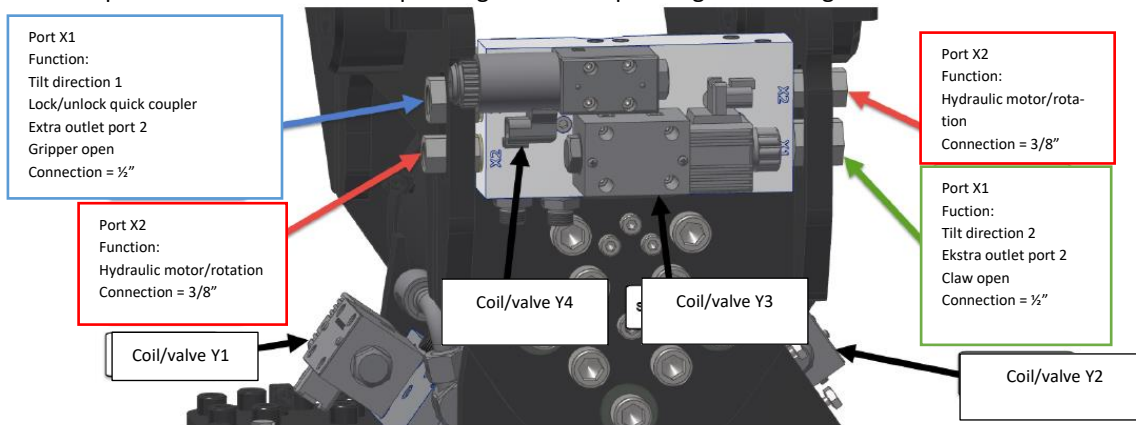

Hydraulic diagram CTR10 hydraulic system HS4

Hydraulic schedule
Compact Tiltrotator
CTR10-1 HS4

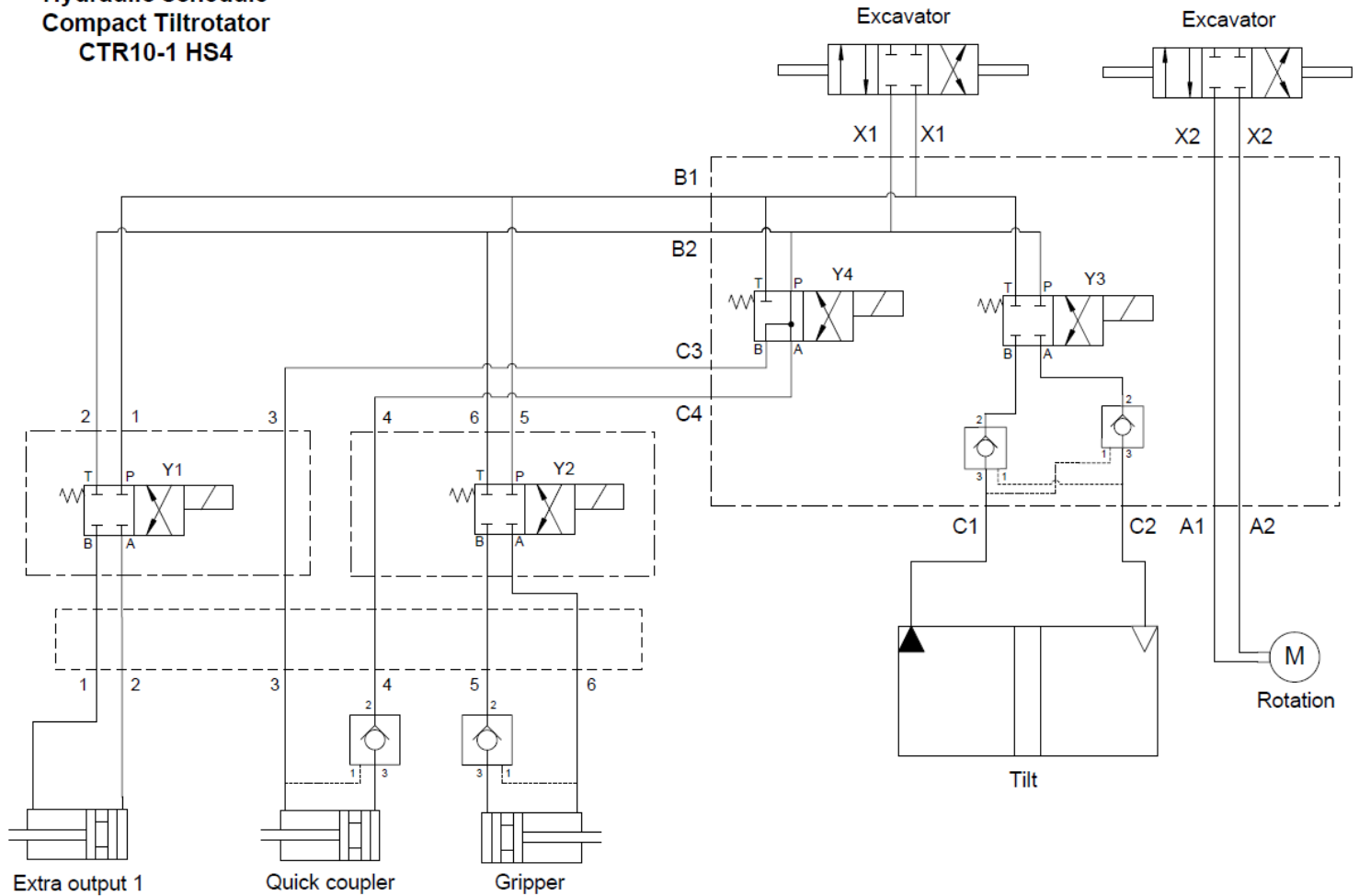

Installation of CTR10 hydraulic system HS4 HF

Before starting the installation of hydraulic hoses, the machine must be switched off and the hydraulic system pressureless.

Hoses are pulled so that there is no squeezing or risk of squeezing when using the machine and connected equipment.

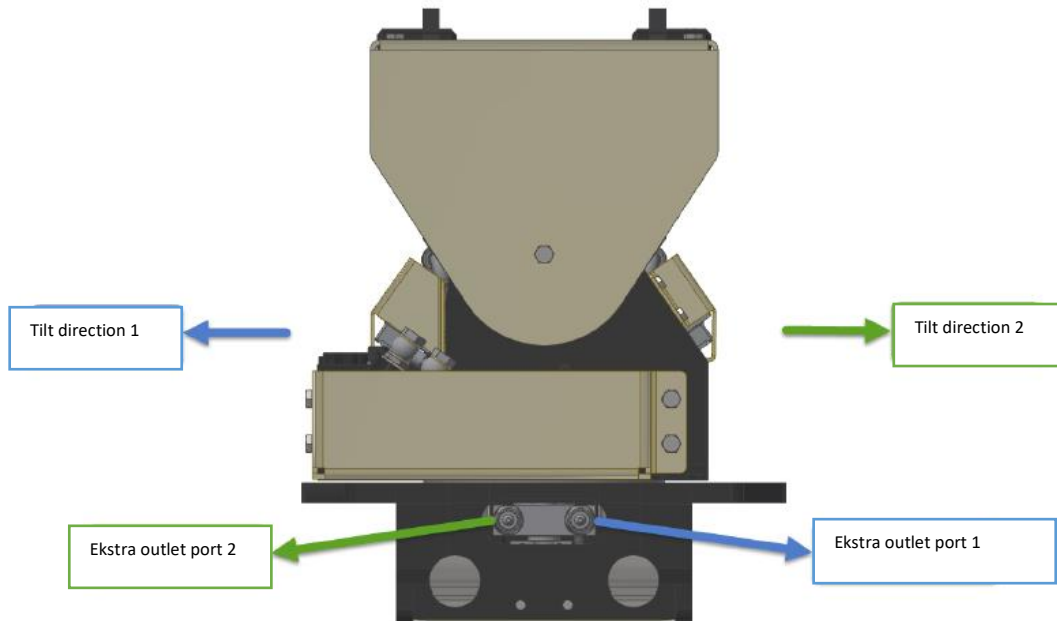
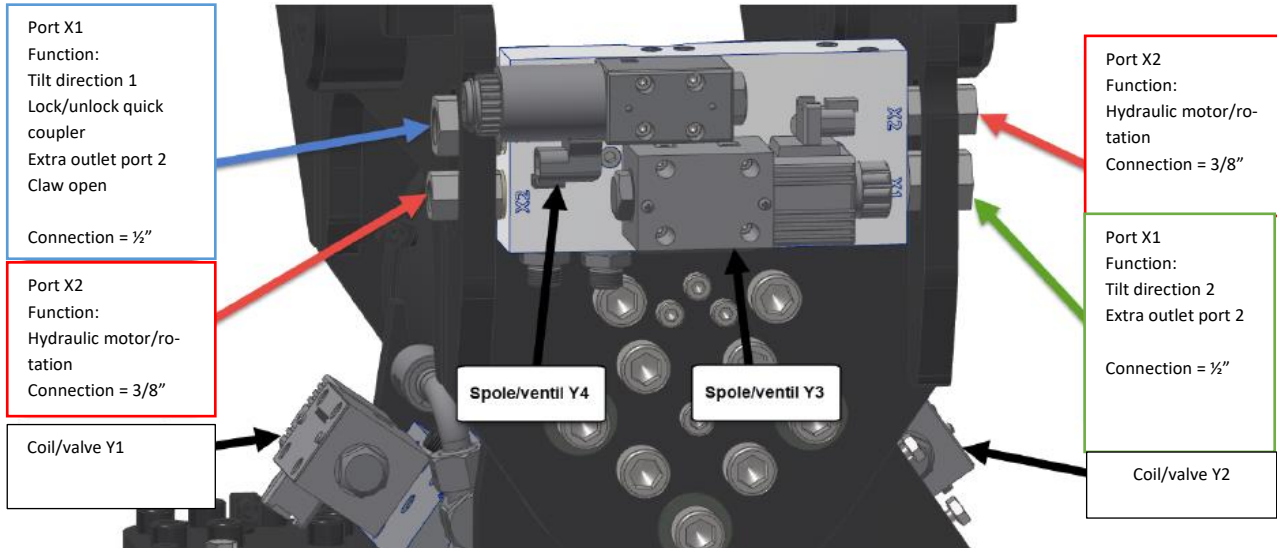

Hydraulic diagram CTR10 hydraulicsystem HS4 High Flow

Hydraulic schedule
Compact Tiltrotator
CTR10-1 HS4 High Flow

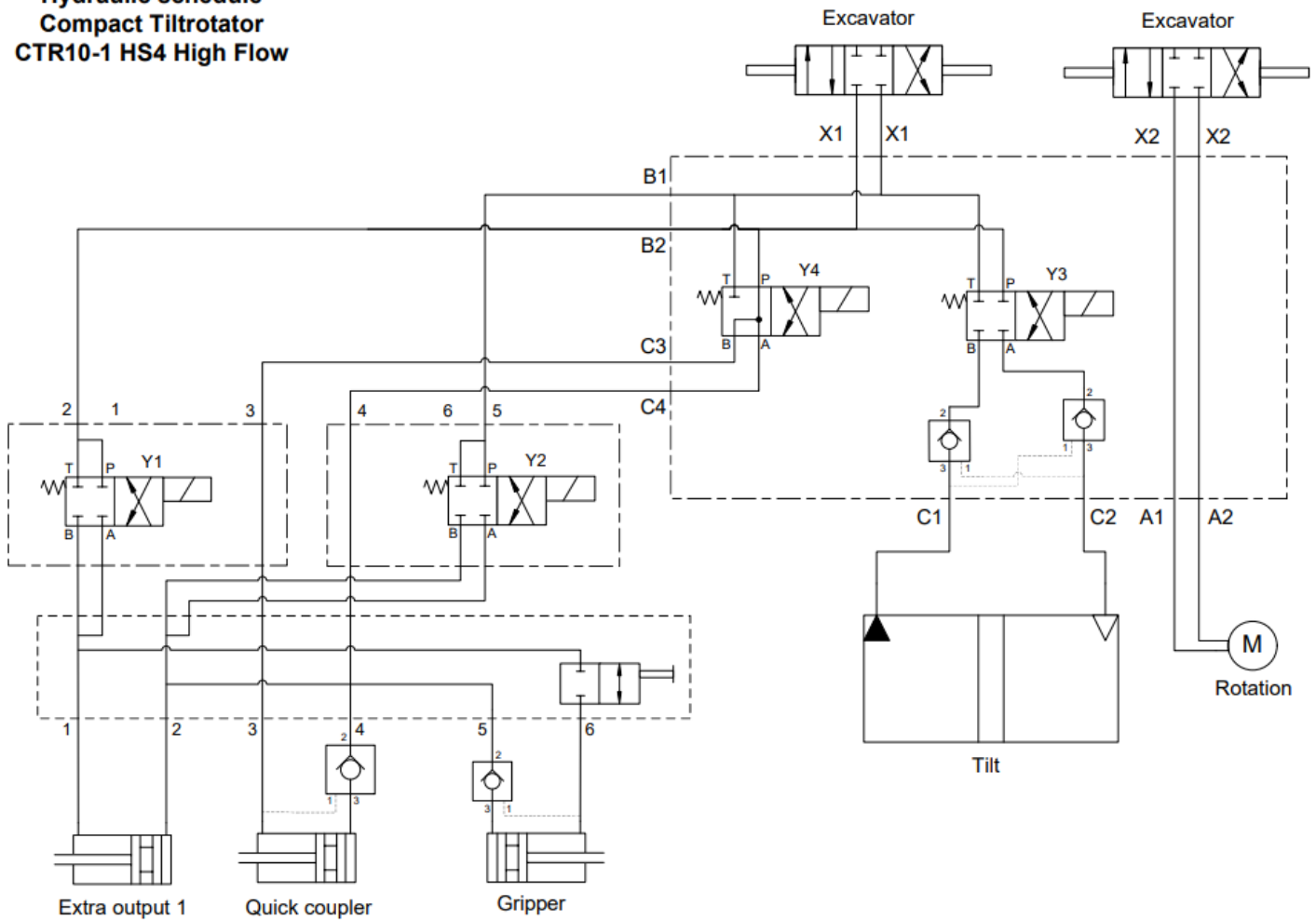

Installation CTR10 hydraulic system HS8

Before starting the installation of hydraulic hoses, the machine must be switched off and the hydraulic system pressure less.

Hoses are pulled so that there is no squeezing or risk of squeezing when using the machine and connected equipment.

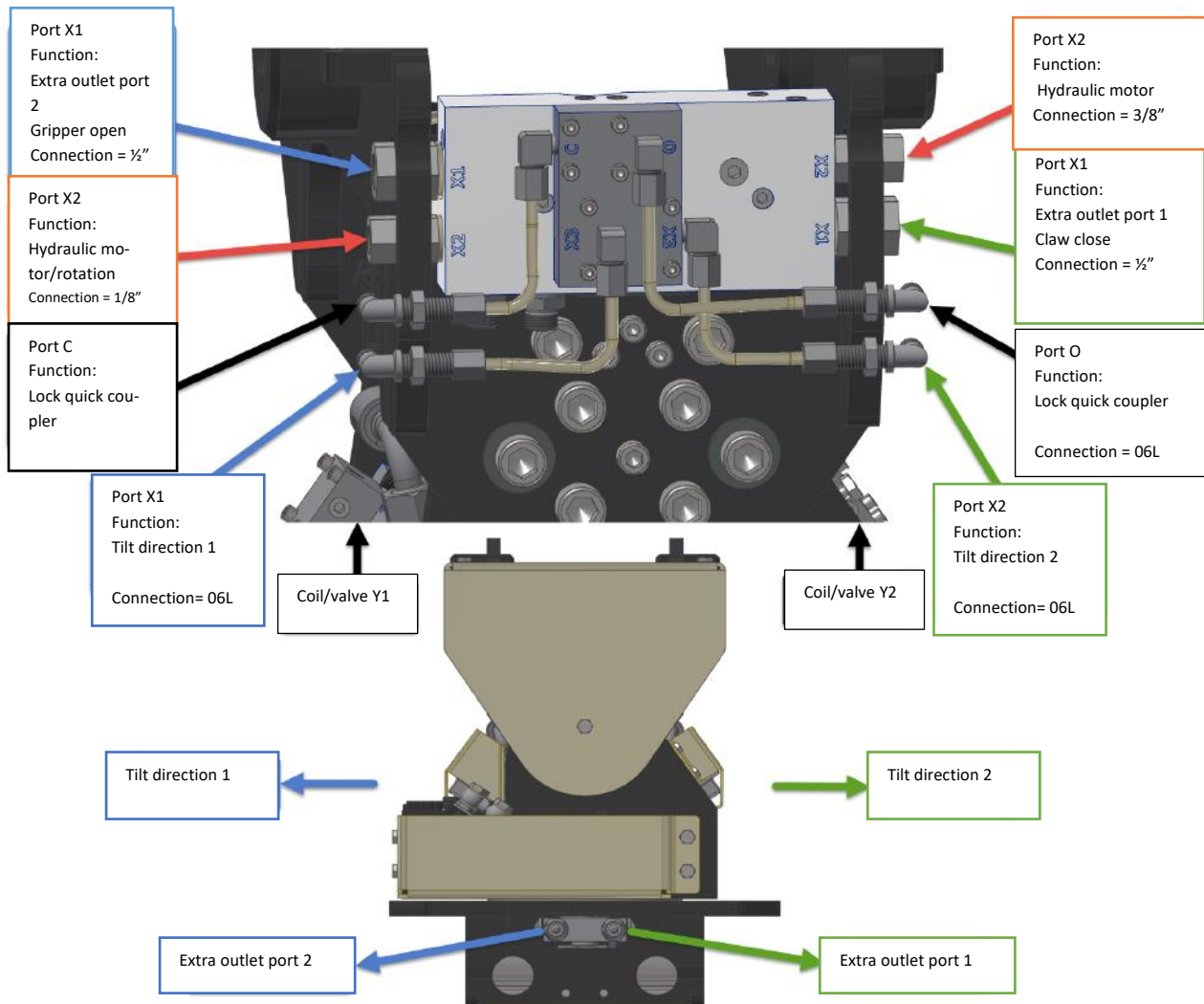

Hydraulic diagram CTR10 hydraulic system HS8

Hydraulic schedule
Compact Tiltrotator
CTR10-1 HS8 w. switch

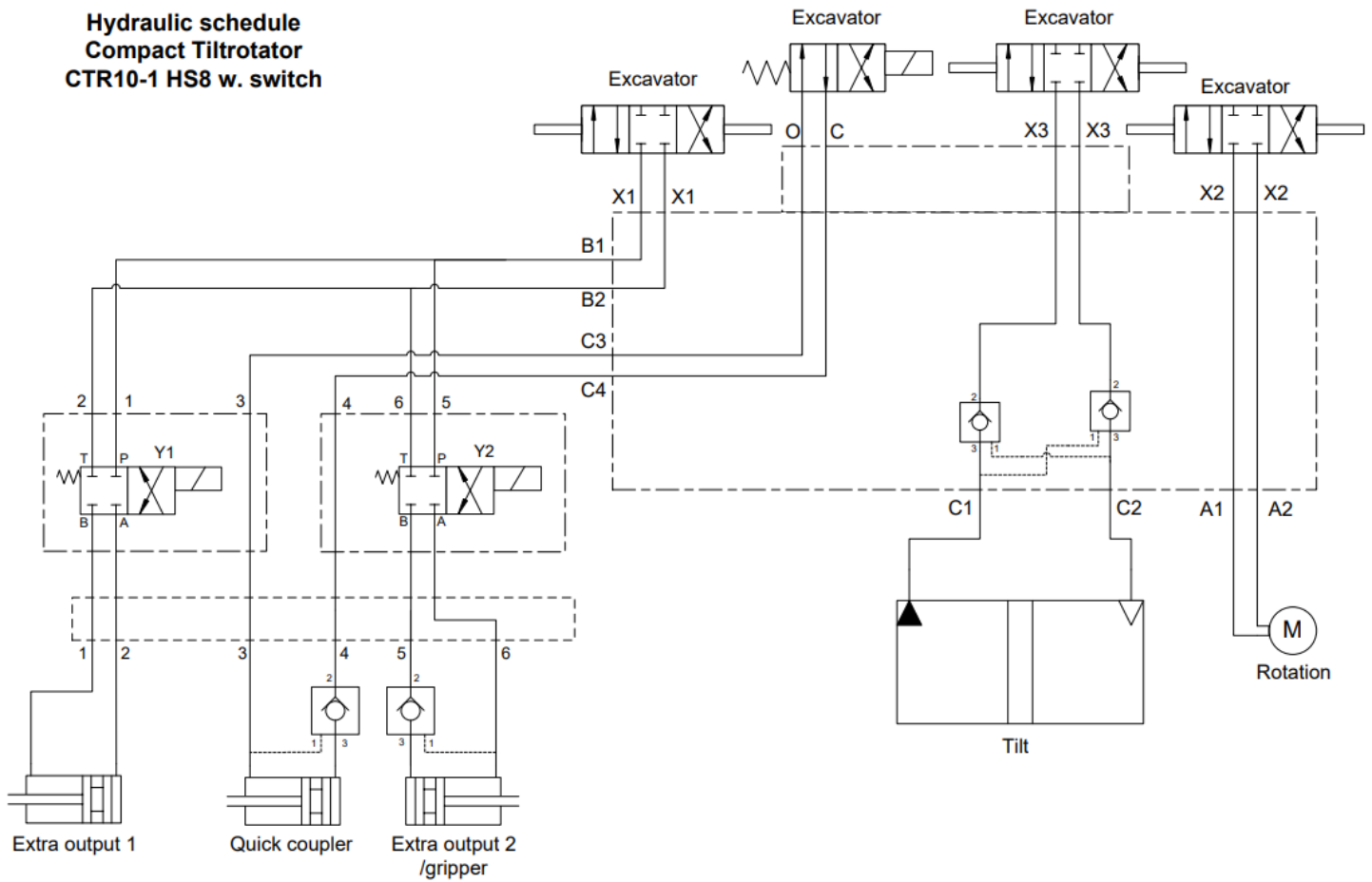

Installation CTR10 hydraulic system HS8 HF

Before starting the installation of hydraulic hoses, the machine must be switched off and the hydraulic system pressure less.

Hoses are pulled so that there is no squeezing or risk of squeezing when using the machine and connected equipment.

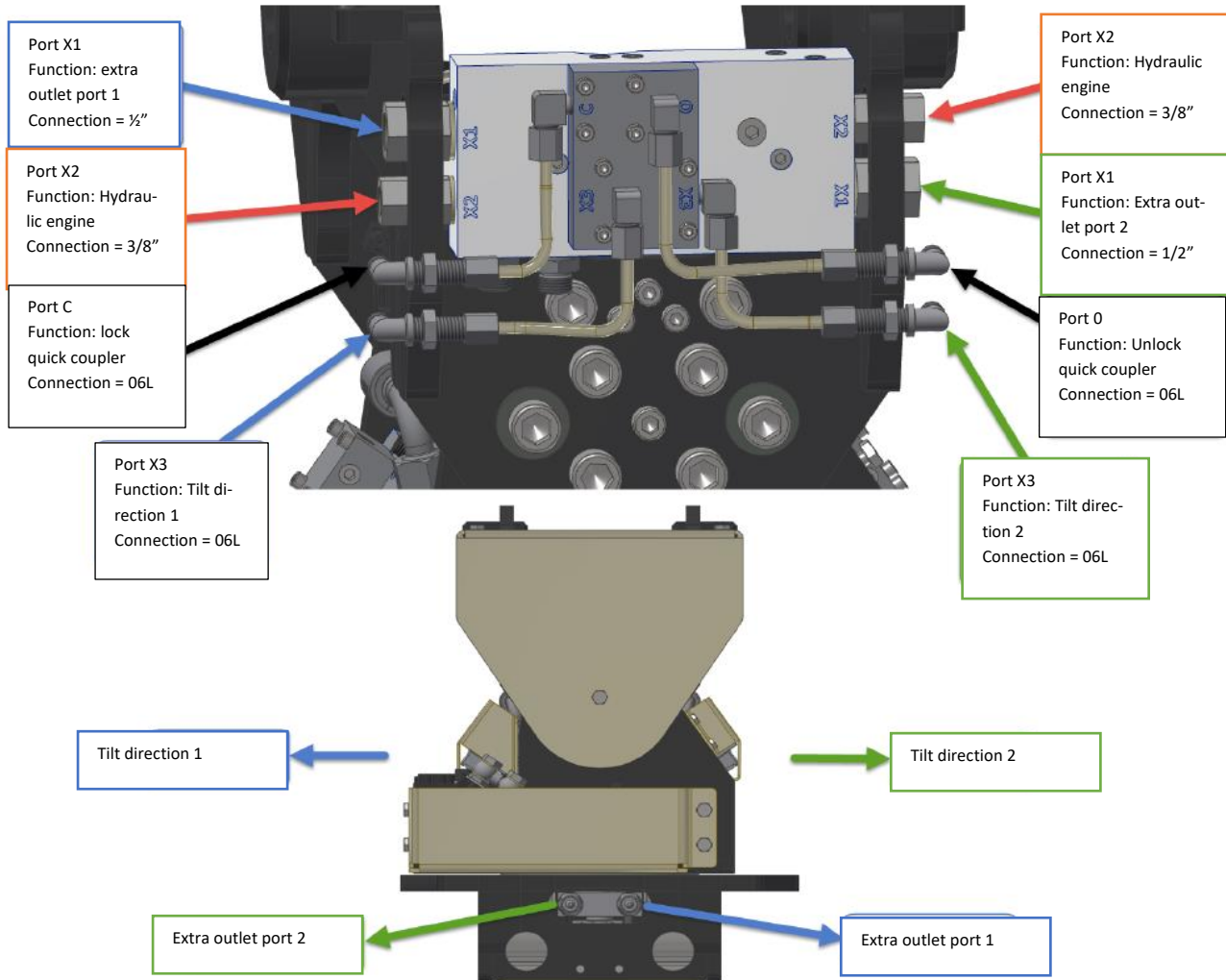

Hydraulic diagram CTR10 hydraulic system HS8 High Flow

Hydraulic Schedule Compactilt CTR10-1 HS8 High Flow

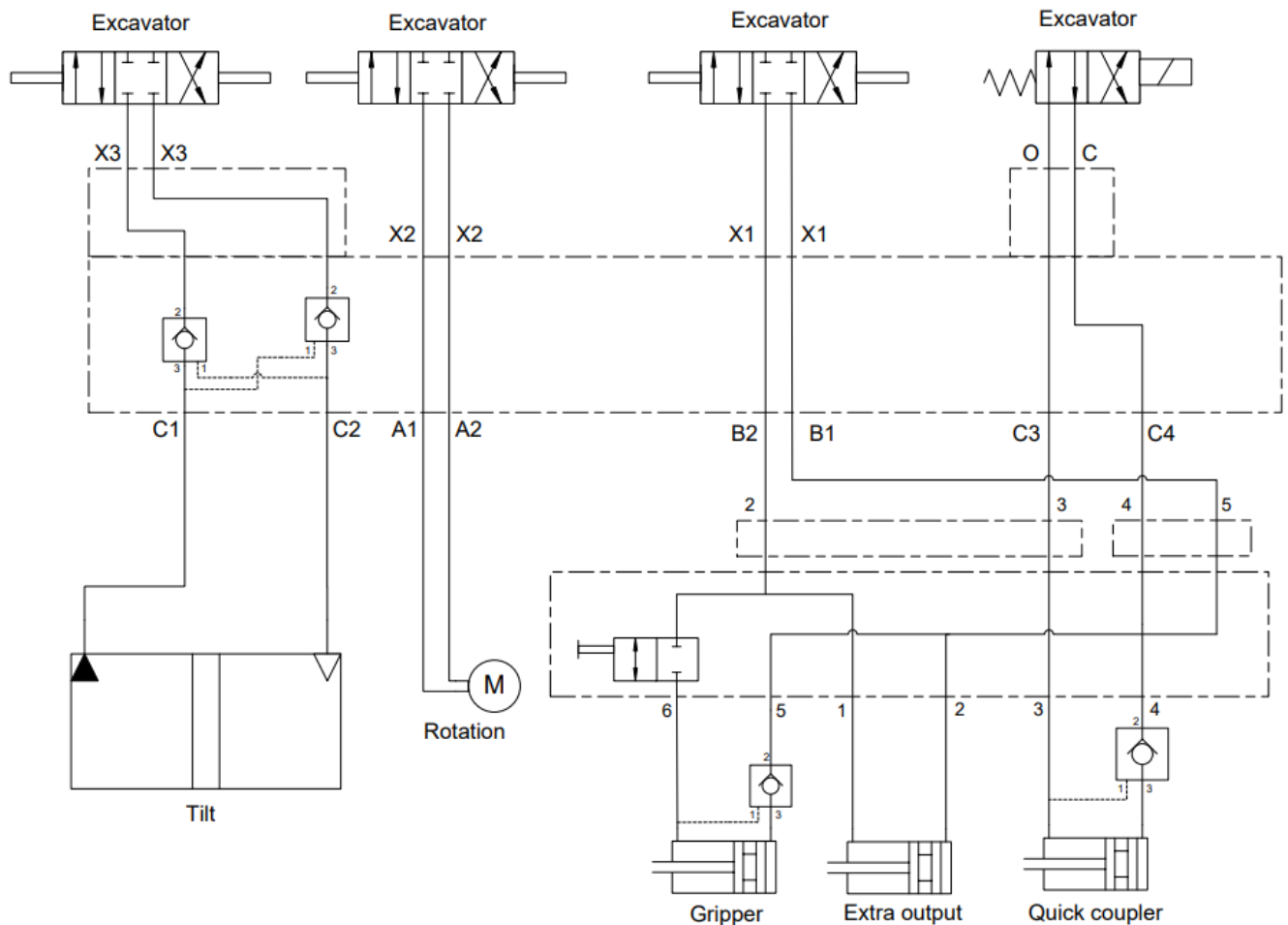

Manuel switch between gripe and extra outlet

Manual switching is performed with a 7 mm socket wrench with shaft (included).



The extra outlet is always active when the claw is activated. Additional outlets can only be deactivated by removing the hydraulic coupling.

The claw can be activated / deactivated manually without disassembling the hydraulic coupling using this manual:

1. Turn the adjusting screw (right) in the swivel block high flow to stop, puts the claw out of operation and only the extra outlet is active (with high flow).
2. If the adjusting screw (left turn) is turned in swivel block high flow to stop, the claw and extra outlet are active again.

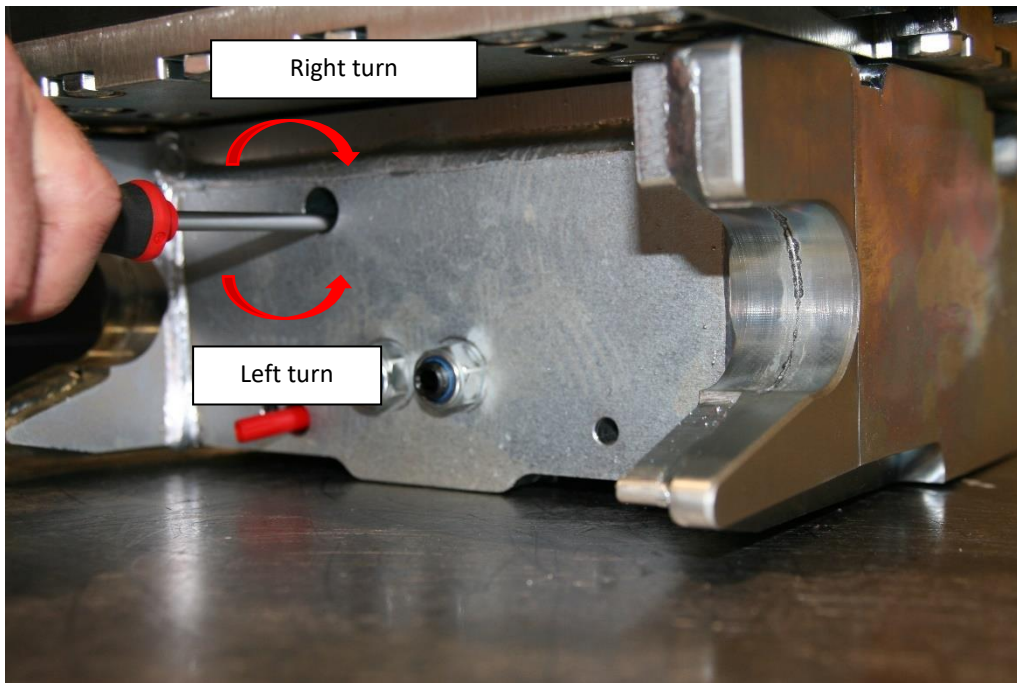

Connection of equipment

Before coupling the equipment, make sure that the quick coupler locking pawls are retracted, which can be seen by pushing out the indicator pin (Figure 5).

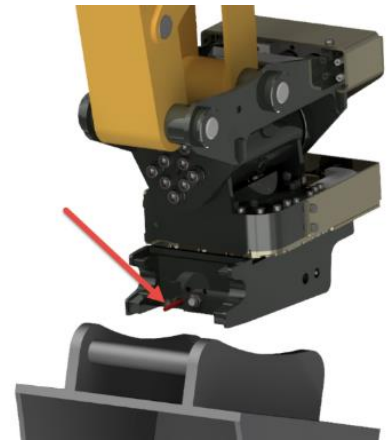

Figure 5



Figure 6

The equipment to be connected must be positioned so that the quick coupler fork eyes can catch.

The quick coupler fork eyes engage the coupling shaft of the equipment (Figure 6).

When the quick coupler fork eyes have caught, the equipment is swung into place thus it abuts the open fork eyes of the quick coupler. The quick coupler is activated, and the locking pawls are pushed out (Figure 7).

The activation of the quick coupler can be seen by the retraction of the red indicator.

The operator tests that the equipment is correctly locked by pressing it against the surface.

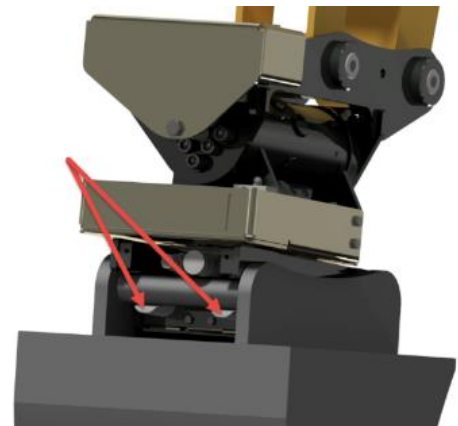

Figure 7

The machine is now ready for use with the connected implement.

Quick coupler with valve system



Installation inspection

1. Check that the Compacttilt Rotator functions correctly.
2. Check that hoses and electric cables are not in risk of being pinched or stretched.
3. Check for hydraulic leaks.
4. Check that fasteners are properly tightened [see machine instructions].
5. Check that there is no contact with the digging arm and the Compacttilt Rotator at full swing.
6. Check that the tiltrotator mounting bracket fits the carrier machine [see type plate].
7. Ensure that the pin-lock is fully engaged, and the indicator pin is correctly mounted.

NOTE: Assembly and installation may only be carried out by workshops approved by the manufacturer. Do not make any changes to the assembly without the manufacturer's permission. Workshops approved by the manufacturer are dealers with their own workshop, unless otherwise stated in the delivery of the Compacttilt Rotator.

Steering range – Compacttilt Rotator

Compacttilt Rotator has the following control angle which must be taken into account

1. Rotations function 360° (*Figure 8*)
2. Tilt function på 2 x 50° (*Figure 9*)

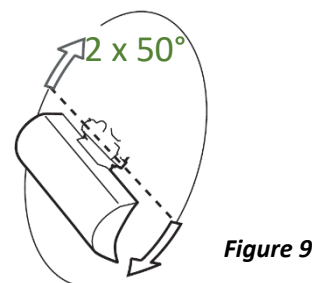
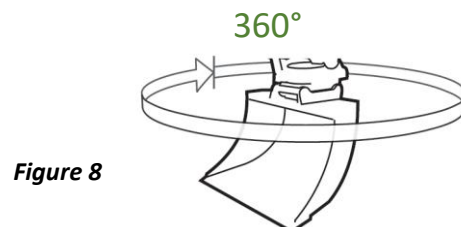

Safety – Hydraulic quick coupler

Compacttilt The rotator quick change is fitted with strong springs to ensure that buckets and equipment are not released in the event of a hose breakage or internal leakage in the bucket hydraulic cylinder.

Compacttilt Tiltrotator must not be used if the springs are damaged or removed.

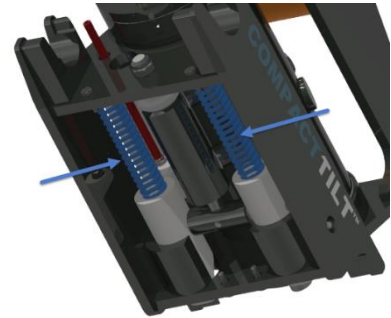

Extra outlet

Compacttilt rotator is equipped with 1 set of extra outlet, see the following data box:

Compacttilt Rotator	Quick coupler
CTR2	Iso-A 1/4"
CTR3	Iso-A 3/8"
CTR10	Iso-A 1/2"

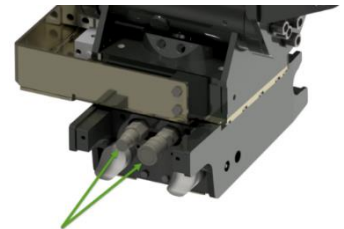

Lifting hook – use and limitations

Application

This illustration (Figure 10) is taken from the standard DS / EN 474-1, which describes how to use the lifting hook (Figure 11). However, it is not required that there is a lifting hook on one's Compacttilt product, and therefore there will be no requirement for the customer about this. See the inscription on the hook for max. capacity load. Human lifting is prohibited.

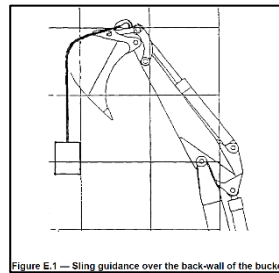

Figure E.1 — Sling guidance over the back-wall of the bucket

Figur 10



Figur 11

Gripper – Use and restrictions

Use

The standard DS / EN 474-1 and ISO: 13031 describes how to use the gripper (Figure 20). However, it is not required that there is a gripper on one's Compacttilt Rotator product, and therefore there will be no requirement for the customer about this.

Typically, the gripper is used for the following tasks:

- Handling of posts and curbs
- Establishment of wells and laying of pipes
- Forestry



Figure 20

Restrictions

The claw has the following limitations, in relation to what may be used for:

- Max capacity has been tested and approved for 1,500 kg
- May only be used for what the machine allows [See carrier's instructions].

Risk

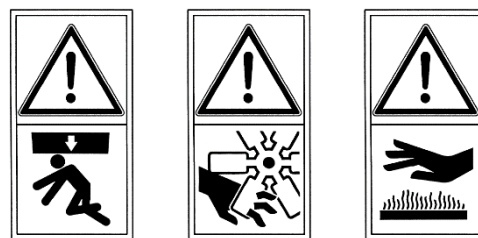

Hot surface, crushing & cutting hazard

- There is a risk of hot surface both before and after using the gripper.
 - Therefore, always wear work gloves that are approved for use with hot objects.
- There is a risk of crushing when using the gripper, and personal injury may occur.
 - It is strictly forbidden to stay under the Compacttilt Rotator with gripper when it is in use.
- There is a risk of cutting when using the gripper, and there may be personal injury.
 - It is therefore strictly forbidden to be under or in the axis of rotation of the machine when the Compacttilt Rotator with gripper is mounted.

Decoupling equipment

The bucket / equipment is lowered so that it supports a solid surface (Figure 13).



Figure 13

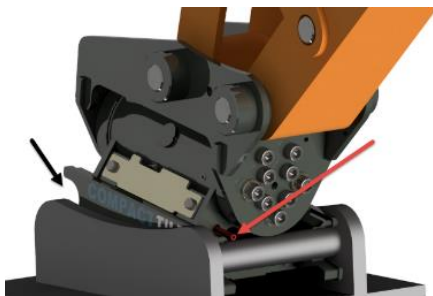

Figure 14

The coupler lock is unlocked by the operator until the indicator pin has been extended. This releases the tilt locking pawls of the tilt shaft (Figure 14).

With the coupler lock open, the tilt is now moved away from the bucket / equipment (Figure 15).



Figure 15

Lubrication overview

For lubrication of the Compacttilt, it is recommended to use: **Castrol Molub-Alloy 370-2**
Lithium-based high-pressure grease with min. 3% molybdenum disulphide (MoS₂) EP additives in NLGI 2.

Spec.: -DIN 51502 KF2K-25
 -ISO 6743-9 ISO-LXCCIB2

Greases containing graphite and copper must not be used.

Always ensure that the lubrication nipples are free of dirt before lubrication is carried out.

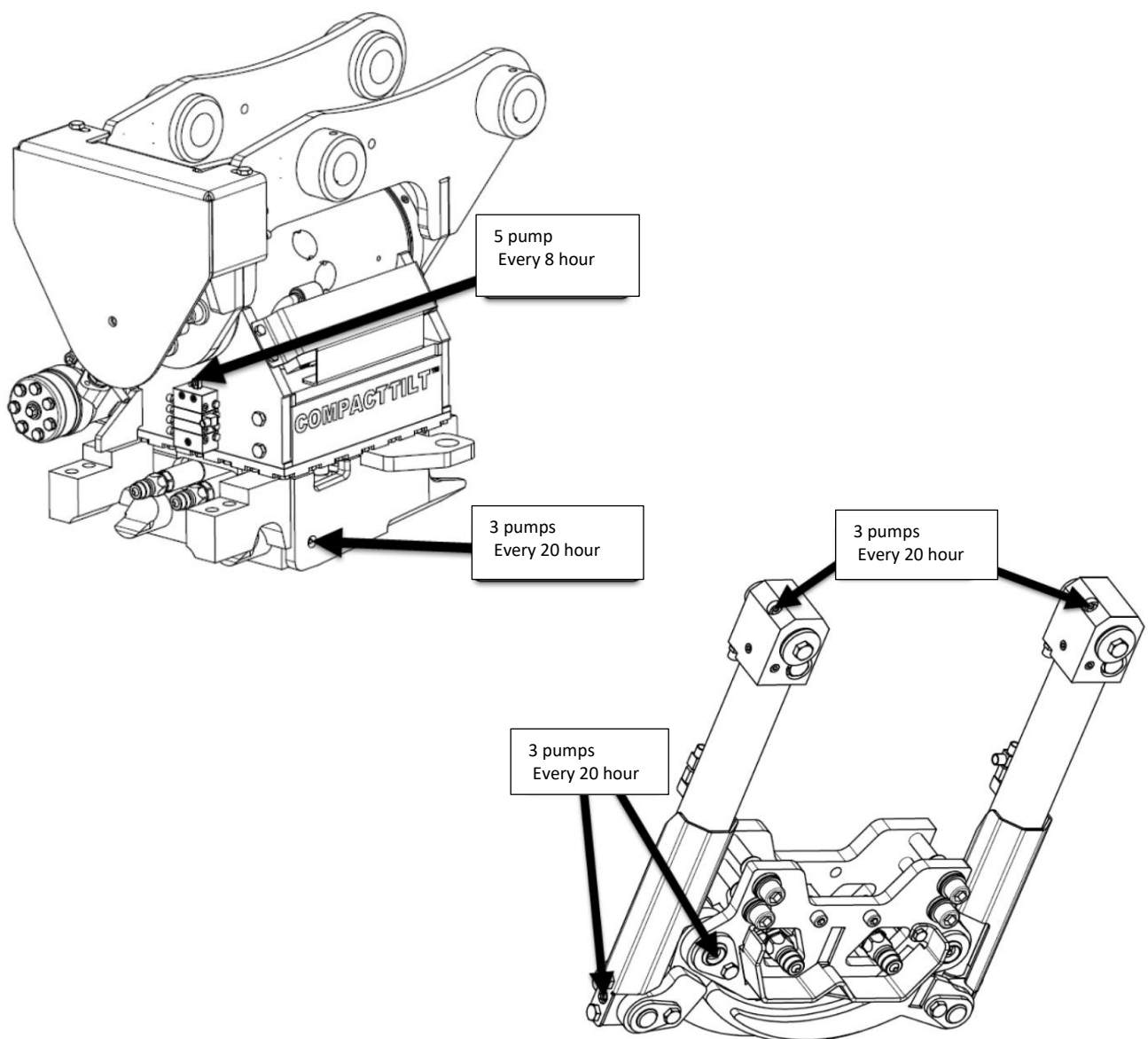

COMPACTTILT™

COMPACTTILT™ ROTATOR™

Compactilt™ is sold by your machine dealer.

Do you have technical questions about Compactilt's products?
Contact your machine dealer for service, further product information and technical advice.

Become a part of
Compactilt's forum:



You can see many
more pictures here:



Watch all movies from
Compactilt™ here:



Link you to
Compactilt's network here:

