



COMPACTTILT™

USER MANUAL
INSTRUCTIONS
PRODUCT INFORMATION

CT2, CT3, CT6, CT10

Patentno.:
PCT/DK2016/050047

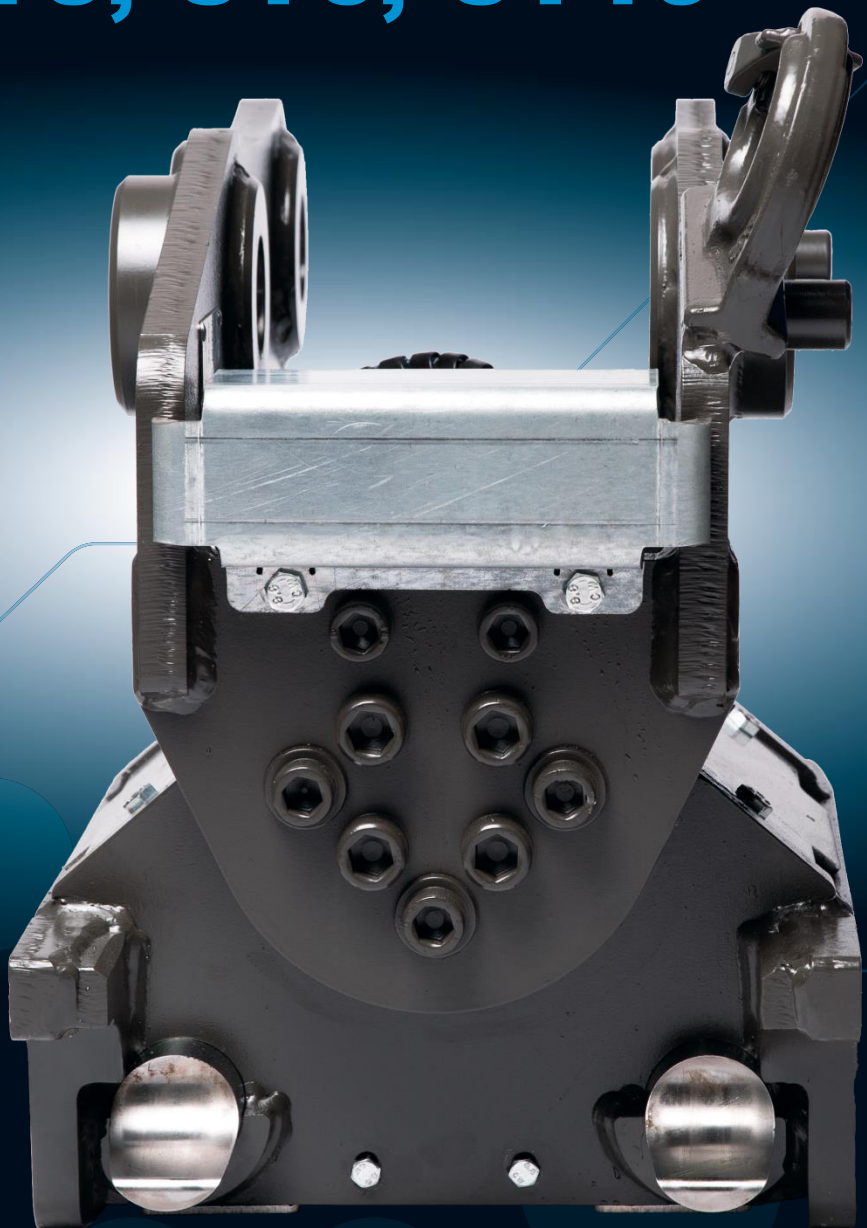

Congratulations on choosing Compacttilt!

We are happy that you have chosen our product - and look forward to it working for you.

Here at Compacttilt, we develop and create products based on the vision of creating the best user experiences. Therefore, it is also important for us that you remain satisfied with your Compacttilt product, and if something unexpected arises or questions - contact us or your machine dealer.

Compacttilt products are our own development and is manufactured in 380Invent's factory in Denmark. This means that each part of the product is engineered based on our vision of what supplies the best tilt product. But we cannot avoid the fact that maintenance and correct use of the product is the way forward, for full utilization of the product's lifetime. Therefore, read this instruction and perform the maintenance according to the regulations.

Again, congratulations on your choice of Compacttilt. We look forward to a long and good cooperation. Just contact us for more information.

Daniel Duus,
CEO of 380Invent and product engineer of the Compacttilt.dk product line
Compacttilt.dk // 380Invent

Compacttilt is a patented and protected product: The full ownership of all intellectual property rights regarding the product's manufacture, design, trademarks and copyrights, belongs to 380 ° Invent ApS.

Compacttilt™ lives up to PLc cf. DS / EN ISO 13849-1: 2015.

Appendix

- EC- Declaration of conformity
- Certificat: Lifting Hook
- Safety instructions
- Warning – Prohibition – Reminders
- Technical data Compacttilt
- Installation
 - Use of quick change with valve system
 - Decoupling the bucket
 - Lifting Hook - Use and Restrictions
 - Safety - Hydraulic quick change
- Maintenance
- Sparepart list
- Service book

EC declaration of conformity

According to The Machinery Directive 2006/42/EF, Appx. IIA



Manufacturer:

380°Invent ApS
Fabriksvej 5
5580 Nørre Aaby, Danmark
Tlf.: +45 6442 2080

Hereby declare that the following equipment:

Product: Compacttilt™

Type:

CT2	CT3	CT6	CT10
-----	-----	-----	------

Serie no _____

Year: _____

Complies with the following directives:

2006/42 / EC Machinery Directive

The following harmonized standards have been applied:

DS / EN ISO 12100: 2011 Machine safety - General principles of construction - Risk assessment and risk reduction

DS / EN ISO 4413: 2010 Hydraulics - General rules and safety requirements for systems and their components.

DS / EN 474-1: 2006 + A5: 2018 Earthmoving machines - Safety - Part 1: General requirements

ISO 13031: 2016 Earth-moving machinery - Quick couplers - Safety

DS / EN ISO 13849-1: 2015

Safety of machinery - Safety related parts of control systems - Part 1: General principles of construction

Place / Date

Name/Title Maria Gade, Administrator

Signature

The undersigned is the representative for the collection of the technical dossier

Certificat: Lifting Hook

See application and restrictions further down in the manual.



TEST CERTIFICATE		H-LIFT INDUSTRIES CO.,LTD.			
		8/F., No. 560 Jincheng Road, Xiaoshan, Hangzhou, 311202, China Tel + 86-571-8263-6008, Fax + 86-571-8263-6028 http://www.h-lift.com E-mail: info@h-lift.com			
		CERTIFICATE NO.		ZS-14319-029	
		SUPPLIED TO		SORENSEN & KOFOED A/S SMEDEHOLM 7-9 2730 HERLEV DENMARK	
YOUR P/O NO.:		00059679-2		INVOICE NO. 14HC319	
(1) Description of Gear					
GRADE 80 WELD ON HOOK TESTING ACCORDING TO EN 1677 MATERIAL: ALLOY STEEL					
(2) PRODUCT CODE	(3) SIZE(t)	(4) QUANTITY (pcs)	(5) WORKING LOAD LIMIT(WLL)	(6) MIN. BREAKING FORCE (BF)	(7) MARKING
8-WOH-02	2	100	2t	98kN	WLL2T CE
8-WOH-03	3	120	3t	147kN	WLL3T CE
8-WOH-05	5	40	5t	245kN	WLL5T CE
8-WOH-08	8	20	8t	392kN	WLL8T CE
I hereby certify that the item described in this certificate was tested and thoroughly examined and that the above particulars are correct.					
TEST RESULT			CERTIFIED BY:		
Pass <input checked="" type="checkbox"/>	Fail <input type="checkbox"/>		AUTHORISED SIGNATORY:		
			DATE (dd/mm/yy):		
					06/09/14



Add: 8/F., No. 560 Jincheng Road, Xiaoshan, Hangzhou, 311202, China
Tel +86-571-8263-6008 Fax: +86-571-8263-6028 http://www.h-lift.com Email: info@h-lift.com



Safety instructions

This instruction manual must be thoroughly read by any user of the Compacttilt before use. The Compacttilt may only be used for the purposes described in this manual.

The Compacttilt is a quick-coupling equipment that connects the carrier with an implement - therefore user instructions and safety instructions from these two products must always be understood and complied with before the product is used.

Compacttilt™ follows PLc cf. DS / EN ISO 13849-1: 2015.

Compacttilt™: purpose and function

- To give the excavator increased flexibility, so as the Compacttilt is mounted between an excavator's arm and a attachment such as a shovel. Compacttilt adds the function that the attachment can be tilted.
- NOTE: The weight of the Compacttilt and the increased range can lead to impaired stability which in the worst case can lead to personal or property damage.
- The Compacttilt is only for use in implements intended for excavators and must not be used for other purposes.

Restrictions on use

The Compacttilt is only intended for use with digging implements. It is not recommended to use the Compacttilt for oil hammer / hydraulic hammer, as it significantly reduces the service life of the Compacttilt.

Compacttilt must not be used with a crane arm, for transporting or lifting people.

Before Use

- This instruction only involves the Compacttilt - the safety information described will at all times depend on the carrier, where the applicable safety instructions and lifting graphs for the carrier as well as any other equipment, to be read and understood at all times before commissioning and subsequently complied with.
- It is ensured that the information in the declaration of conformity corresponds to the information plate mounted on the Compacttilt. If there are deviations, contact the supplier immediately before carrying out the installation.
- Make sure that the hydraulic system is depressurized before you start working on the system.
- It is strictly forbidden, at any time, that:
 - Stay under the Compacttilt.
 - To influence, sabotage or manipulate the Compacttilt using 3rd party objects.
 - To use the Compacttilt for other machine types than the specific one for which it is manufactured, cf. the type plate.

Before Daily Use

- The mounting points are safety components that require regular inspection and adjustment. In the event of signs of wear or cracking, the Compacttilt must not be used.
- Always follow the instructions and pay attention to the personal and environmental instructions in the data sheet that comes with hydraulic oil and grease.
- Never use your hands to check for leaks in the hydraulic system - there is a risk of personal injury.
- When mounting the Compacttilt and / or tool holder, check the limits for tiplast.
- Implements connected to the Compacttilt may only be used if the locking has been carried out correctly.
- Never use the Compacttilt on a damaged or defective machine or bucket.
- Never try to increase the maximum capacity of the machine.
- Always replace damaged or unreadable labels and warning signs before using the machine.
- Always insulate electrical conductors and components when installing electrical equipment.
- There is a risk of burns when in contact with hot hydraulic oil.
- The implement lock may only be activated when the bucket or work implement is switched on and off.
- There is a risk of crushing with moving parts.
- When lifting, use a lifting hook for lifting to the extent that the excavator is approved for.
- If you have any doubts about use and safety instructions, contact your dealer or the manufacturer of the Compacttilt.
- Be extremely careful when handling long objects due to forces due to "live/movable weight" and the increased risk area. Risk of personal injury and property damage.
- The Compacttilt must not be used beyond the maximum capacity.

- It is not permitted to manipulate or otherwise change the installation and / or function of the Compacttilt.
- Maintenance and repair may only be performed by professionally trained personnel.
- Assembly and installation may only be carried out by an authorized workshop.
- Do not start the tool without:
 - The tool is set correctly, including that the mechanical locking device is set correctly.
 - It is ensured that hoses, hydraulics etc. does not bother the Compacttilt and its features.
 - The operator and the third party are not under the tool and / or in the working area of the tool, where the hazardous squeezing situation may occur.
- Especially for the Compacttilt valve system:
 - Always test the valve function every morning before starting, to ensure that the valve system is fully functional. This is done by making a full turn until both are seated and then checking that the locking pawls are not unlocked when tilting.
NOTE. if this is not the case - contact your service center.
 - Checks for leaks. The Compacttilt must not be used if leaks are found on the valve system.
 - Pay attention to wear on hoses. In the event of signs of wear, these must be replaced immediately.

Regular security checks

- Inspection of hydraulic hoses, fittings, pipes and joints.
- Inspections of welds and suspensions.
- Inspections of forks wear
- Inspections of lock

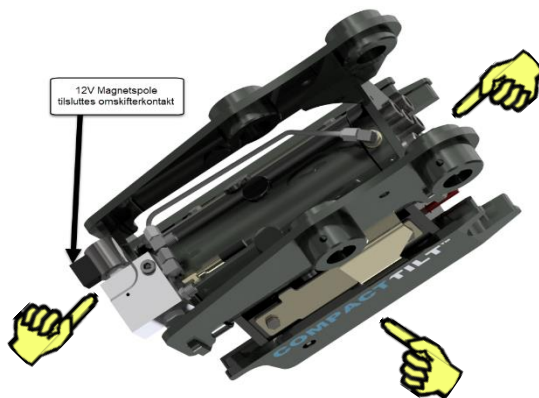

The manufacturer require attachment control
The manufacturer require checking the locking pawls,
damage occurs, contact servicesupport



- Only instructed personnel may operate the machine part.
- The operator must pay attention to proper fastening of the machine part before start-up.
- The machine part must not be installed with irregularities and must be notified to the person in charge immediately.
- Everyone who operates the part must be registered by the person in charge.
- When working and repairing, all moving functions must be in the locked stop.
- When working with the machine part, the manufacturer requires operators to have personal protection.

Moving the product

Always ensure that there are no objects, persons or third-party objects under the product, or with the risk that it may interfere with the movement.

When moving, use correct lifting devices, e.g. truck or crane. Always remember to ensure that the product is properly secured during the move. It is the user's responsibility that lifting straps, or lifting chains, are safety approved for the weight of the product. For truck transport, machine parts must be secured with straps. For crane

lifting, lifting chains / straps must be designed for the weight.

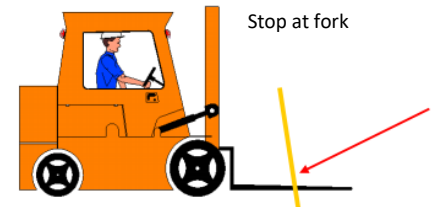

Disposal: Cessation of use and disassembly

A plan for disassembly must be prepared, the plan must include a risk assessment for the work and for disposal of the machines / machine part. Plan and risk assessment must be prepared in accordance with applicable rules at the time of dismantling.

The equipment must not be pressurized during disassembly and must be drained of oil. The product is dismantled and sorted into categories that require in applicable environmental requirements.



The product is subject to: Directive 2008 / EC & Directive 2002 / EC on waste.

The product is obsolete, all the components that make up the machines / machine part must be sorted and handed in at an approved recycling site, or carried out by an approved recycling company.

The product must not be disposed of with unsorted household waste. Use the local WEEE collection points for the disposal of electrical components of this product and make sure that all relevant regulations are observed.

The product consists of the following parts and must be sorted accordingly:

- Iron
- Aluminum
- Plastic (hard & soft)
- Rubber
- Oil & grease
- Electrical components
- Copper
- Other metals

If parts of the machines are resold for purposes other than disposal, it is the owner's responsibility to make the recipient aware of the disposal rules.

Warning – Prohibition - Reminders

 This manual must be available immediately at the machine. If this is not possible, the machine must clearly mark where the manual is stored.

 Other rules, established by national or other authorities or by the company itself, must be observed. If these are violated, the manufacturer and his representative disclaim any responsibility for damage to persons or material.

 The machine must be operated in accordance with the instructions and instructions given in this and the other instructions that together constitute the operating instructions for the machine.

This manual must be read before using the machine.

 All operators and others who must operate the machine must review this manual before working on the machine. By operators is meant all persons working at the machine, both operators and employees who are engaged in e.g. unloading and loading, cleaning, maintenance etc.

Only those persons who need it as part of their work may access the machine.

 If it is necessary to provide access to the machine for persons unfamiliar with the function (eg during repairs, visits or demonstrations), this must be done under the pre-determined safety precautions. The person responsible for the operation of the machine must be informed of the presence of strangers.

 Operators and repairers who are to operate or work on the machine must undergo training in the use of the machine before the work may take place. The manufacturer carries out the necessary training of operators and repairers when handing over the machine.

 If the safety instructions are ignored by the user, the manufacturer and his representative disclaim all responsibility

 If the user changes, disassembles or adds to the original design, mechanical shielding, electrical safety, pneumatics, hydraulics, as well as functions related to the original design, the manufacturer's CE marking

- Only instructed personnel may operate the machine part.
- The operator must pay attention to proper fastening of the machine part before start-up.
- The machine part must not be installed with irregularities and must be notified to the person in charge immediately.
- Everyone who operates the part must be registered by the person in charge.
- When working and repairing, all moving functions must be in the locked stop.
- When working with the machine part, the manufacturer requires operators to have personal protection.

Tecnical data Compacttilt

Data/Compacttilt str.	CT2	CT3	CT6	CT10
Max machine weight of the digger	2.000 kg	3.000 kg	6.000 kg	10.000 kg
Min. installation height [H]	170mm	200mm	235mm	270mm
Width [B]	148mm	198mm	198mm	288mm
Length [L]	200mm	313mm	302mm	381mm
Weight incl. Qyquickcoupler/ex top	21,5 kg	36 kg	53 kg	85 kg
Total swing angle [Tilt]	100°	100°	100°	100°
Tilt angle	2x50°	2x50°	2x50°	2x50°
Max. Hydraulic pressure [MPa]	250	250	250	250
Recommended Hydraulic Flow [L / min]	2-4	3-6	4-12	6-14
Torque [Nm at 210bar]	0,6	1	1	1
Type of semi-automatic shift	3165,2	4220,2	5655,3	9437
Type of quick change	S30	S40	S40/H45	H45
Max. Excavation torque [kNm]	18,2	30,7	41,1	62,1
Max. Breaking torque [kNm]	12,3	20,6	31,1	38,4
* Max. Digging and breaking torque is calculated in relation to the following bucket size. Width height	500/550mm	600/800mm	600/800mm	600/950mm

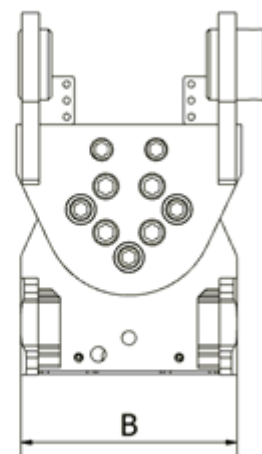
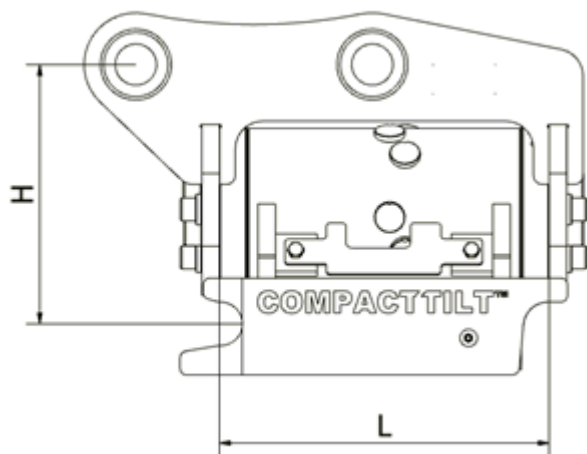

Installation

Prior to installation, make sure that additional documentation on the carrier is available and complied with.

The following describes how to mount the Compacttilt directly on an excavator arm. By

When using the Compacttilt on a tool holder, use the carrier's manual for coupling of implements.

Before start of installation

- Check the limits for tip plastic taking into account the weight of the Compacttilt and the extended range, which may make it necessary to reduce the volume of the bucket, for example.
- Place the carrier on a level and non-slip surface.
- Place the bottom of the Compacttilt on a flat and non-slip surface, making sure the tilt is in neutral position (Figure 1). The digging arm is moved into position so that the arm can be lowered against the Compacttilt's without contact.



Figure 1

Installation

Position the link arm so that its pin bolt hole is flush with the mounting holes in it the fortification (**Figure 2**).



Figure 2

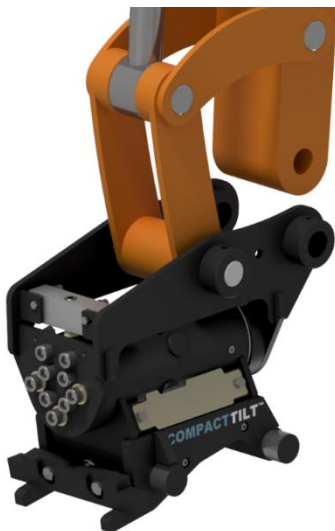

Fit the pin bolt of the link arm and lock it with a bolt or locking pin in the transverse hole of the mounting box (**Figure 3**).

OBS. Use the supplied pin bolts, if supplied.

Lower the main arm into the bracket until its pinhole hole aligns with it the mounting holes in the mounting.

The arm is also locked with a pin bolt corresponding to the link arm (**Figure 4**).



Figure 4

Hydraulic connection

Before starting the installation of hydraulic hoses, the machine must be switched off and the hydraulic system pressure less.

Hoses are pulled so that there is no squeezing or risk of squeezing when using the machine and connected equipment.

Standard Connection

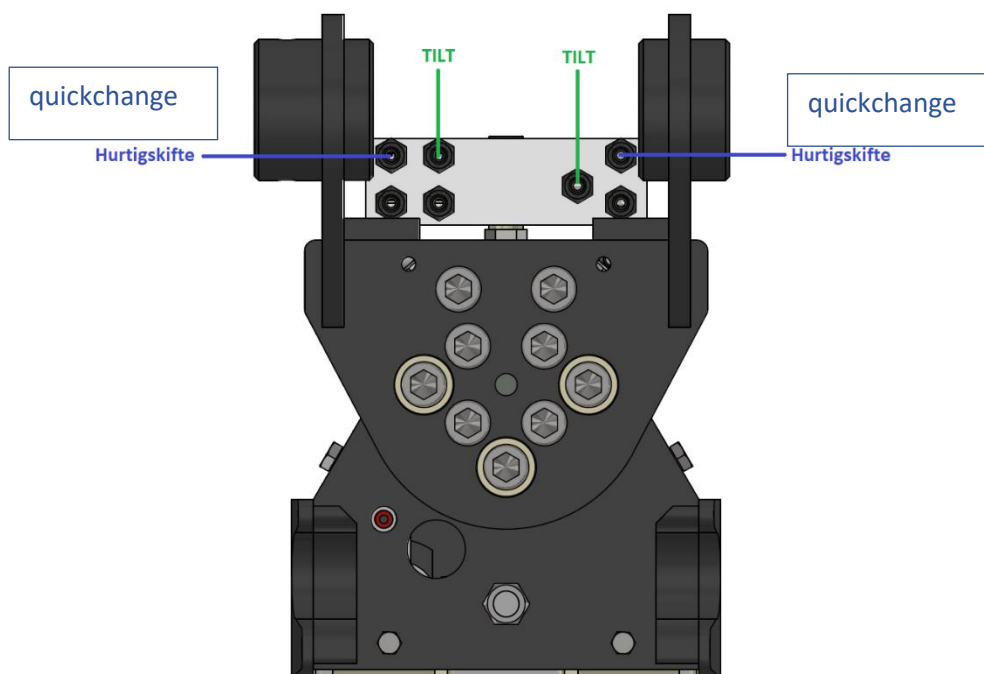

Magnetic coil connection

The magnetic coil connected to an approved switch contact. An acoustic signal is activated, which is active when the magnetic coil is activated. It is the machine dealer's responsibility to ensure that this is done correctly.

COMPACTTILT™

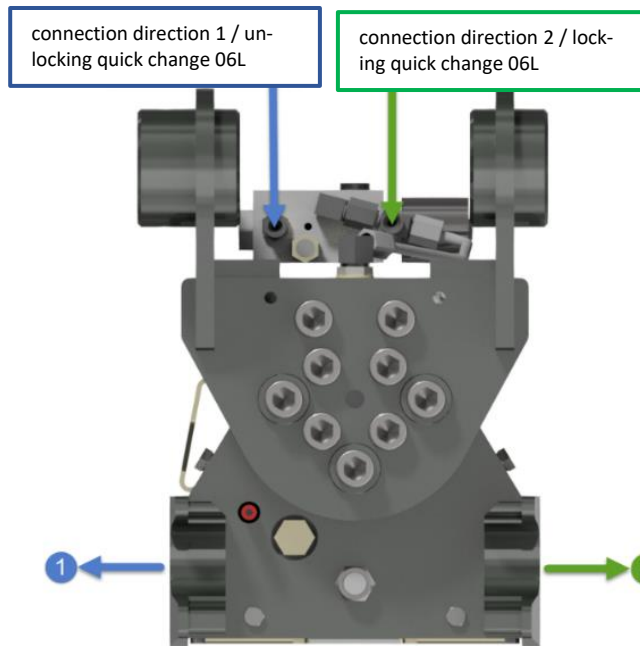
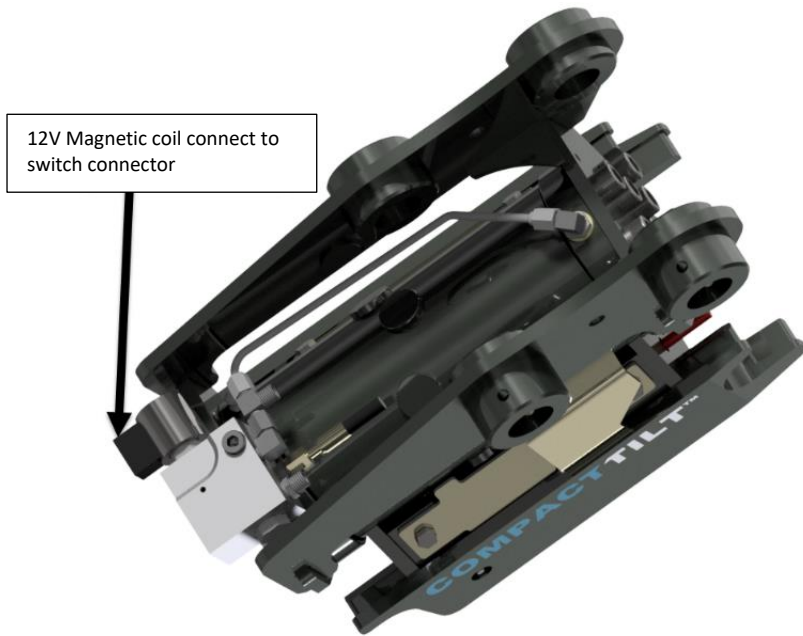

COMPACTTILT™

Connection of Equipment

Before connecting the quick-change equipment, make sure that the quick-release locking pawls are pushed out, which can be seen by pulling in the indicator pin (Figure 5).

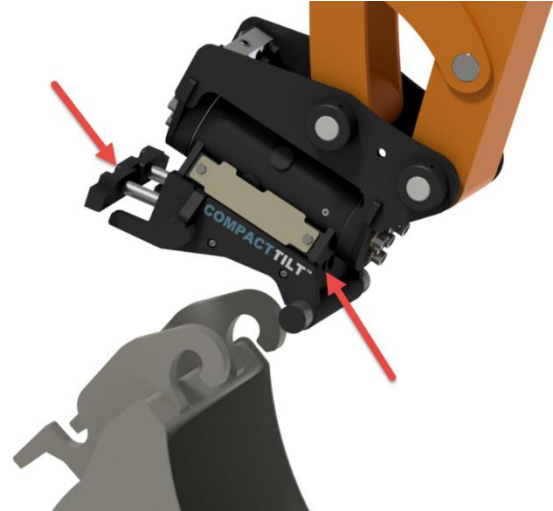

Figur 5

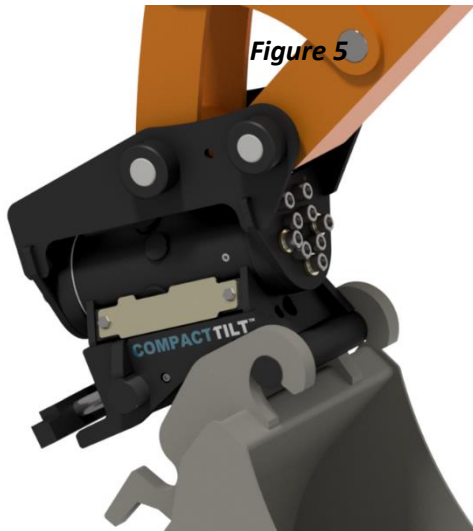

The equipment to be connected must be positioned so that the quick-change shaft can catch.

The quick-change shaft is engaged with the coupling shaft of the equipment (Figure 6).

When the quick-change fork eyes have caught, the implement swings into place so that it abuts against the quick-change shafts. The quick change is activated and the locking pawl is retracted (Figure 7).

The activation of the quick change can be seen by pushing the indicator pin out.

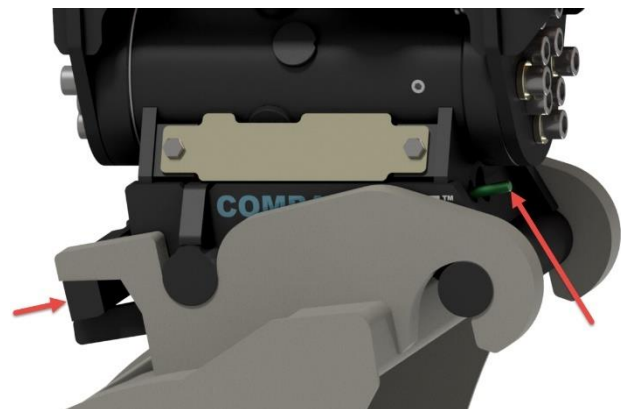

Figure 7

The machine is now ready for use with the connected implement.

1	2	3	4	5
				
activate bucket lock and activate tilt to the right	indicator stick running	shovel is taken off and new shovel is put on	deactivation of bucket lock	shovel is placed against terrain. Tilt to the left

Use of quick change with valve system

Control of installation

1. Check that the Compacttilt is working properly.
2. Check that no hoses or anything else is exposed to pinch, cut or stretch damage.
3. Check leaks.
4. Check that bolts are properly tightened [See carrier's instruction].
5. Check that there is no contact with the digging arm and the Compacttilt at full swing.
6. Ensure that the bracket fits the carrier [see machine sign].
7. Ensures that the pin lock is fully engaged and the indicator pin is mounted correctly.

OBS: Installation may only be carried out by workshops approved by the manufacturer. No modifications may be made to the assembly without the manufacturer's permission. Workshops approved by the manufacturer are dealers with their own workshop, unless otherwise stated before the delivery.

Product Steering range

Compacttilt has the following steering features that must be taken into account:

Tilt function på 2 x 50° (*Figure 8*)

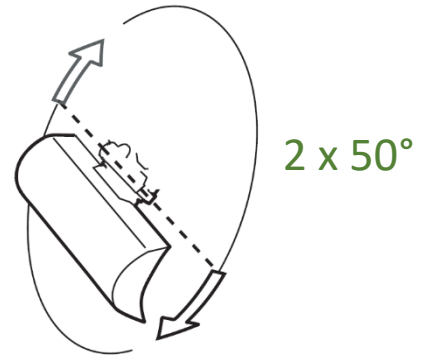

Figure 8

Lifting Hook - Use and Restrictions

Application

This illustration (*Figure 9*) is taken from the standard DS / EN 474-1, which describes how to lift the hook

(*Figure 10*) must be used. However, it is not required that there is a lifting hook on one's Compacttilt product, and therefore there will be no requirement for the customer about this.

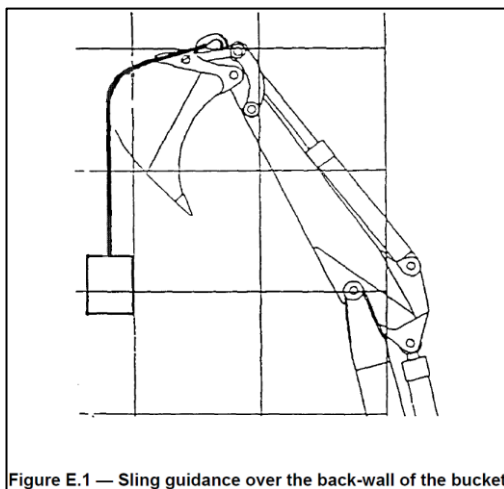

Figure 9



Figure 10

Restriction

There is a maximum capacity load on the following Compacttilt with lifting hook:

Producttype	Max. load [Ton]
CT1	1
CT2	1
CT3	2
CT6	3
CT10	3

Decoupling the bucket

The bucket / equipment is lowered so that it supports a solid surface (Figure 11).



Figure 11



The bucket lock is unlocked by the operator until the indicator pin is retracted. This releases the tilt locking pawl of the tilt of the bucket (Figure 12).

With
from



the bucket lock open, the tilt is now moved away
the bucket (Figure 13).

Figure 13

Safety - Hydraulic quick change

The compacttilt quick change is fitted with heavy-duty springs to ensure that blades and equipment are not released in the event of a hose breakage or internal leakage in the hydraulic cylinder of the bucket lock. The Compacttilt must not be used if the springs are damaged or removed.

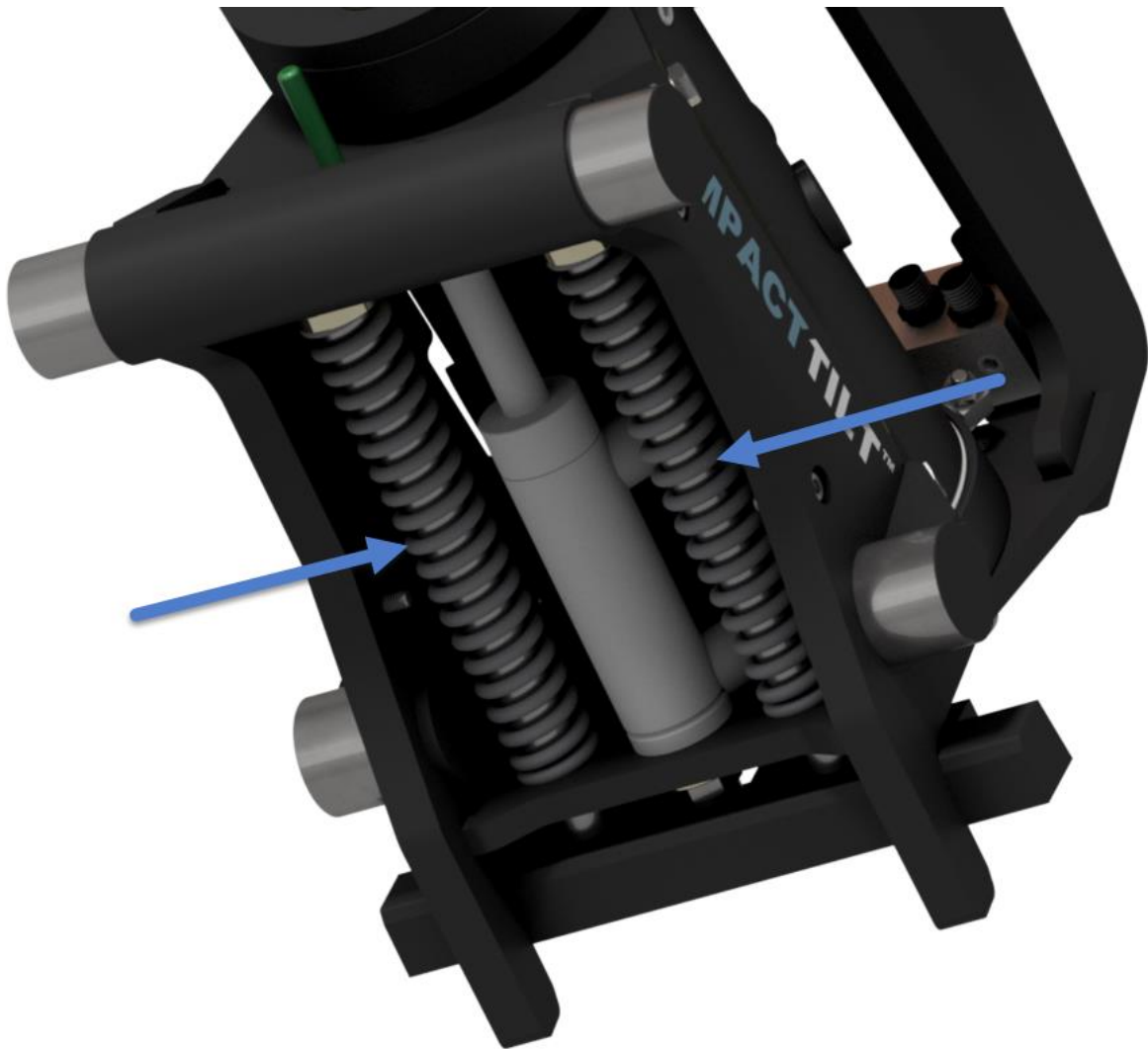

Maintenance

During daily inspection and maintenance, check:

- Lubrication of end bearings. Course of action:
 - Tilt all the way to one side and give 1-2 presses to the grease nipple at each end of the tilt.
 - Tilt all the way to the opposite side, and also give 1-2 presses on the grease nipple at each end of the tilt. Threads are intact

- Eyes and bolts are not broken
- No loose screw joints
- No cracks or fractures
- It is ensured that the tool holder is clean, mounted and clamped correctly
- The Compacttilt is correctly mounted between the carrier and the implement
- There is no hydraulic leak
- There is no grease leakage on hoses or in couplings

Every month or when needed for inspection and maintenance:

- All bolts and screws are inspected and tightened
- Check for unusual wear
- Cleaning of hoses and couplings
- Check for abnormal play. If play exceeds 2 degrees, contact your dealer for service.

Tightening torque:

Bolt size [mm]	Moment [NM] (10.9 bolte)	Moment [NM] (12.9 bolte)
M5	8.1	9,7
M6	14	17
M8	33	40
M10	65	79
M12	114	136
M14	181	217
M16	277	333

Lubrication overview

For lubrication of the Compacttilt, it is recommended to use:

Lithium-based high-pressure grease with molybdenum disulphide (MoS₂) EP additives in NLGI 2.

Spec.: -DIN 51502 KF2K-25

-ISO 6473 ISO-LXCCIB2

Greases containing graphite and copper must not be used.

Always ensure that the spray and lubrication nipples are free of dirt before lubrication is carried out.



Sparepart list

Contact your machine dealer if you have a request for spare parts for Compacttilt.

Servicebook

Date	Service performed by:	Number of operating hours	Notes	Signature for implementation of inspection, including company name

COMPACTTILT™

COMPACTTILT™ ROTATOR™

Compacttilt™ product family

The market's smallest tilt products for machines
in weight class 0-10T



CT1
0 - 1.250 kg



CT2
Max 2T



CT3
Max 3T



CT6
Max 6T



CT10
Max 10T



RTR2
Max 3T



RTR3
Max 3T



RTR10
Max 10T

Version 01 / 2021

380° INVENT
WWW.380.DK

380° Invent

Fabriksvej 5 / DK 5580 Nørre Åby / mail@380.dk / +45 64 42 20 80

380.dk / compacttilt.dk